

---

## PRODUCT BROCHURE



**AIR HEATING AND  
VENTILATION**  
LEO



**AIR CURTAINS AND AIR  
CURTAIN-FAN HEATER UNITS**  
ELiS



**DUCTLESS VENTILATION  
WITH HEAT RECOVERY**  
OXeN



**ROOFTOP UNITS**  
Cube



---

## ABOUT US

FLOWAIR is expert in providing complete cooling, heating and ventilation solutions for medium and big cubature buildings. Our offer consists of four main product groups:

- **air heating and ventilation** fan heaters, gas heaters, electric heaters, mixing chambers, fan heaters for specialized buildings like chicken coops, pools, car washes
- **air curtains and air curtain-fan heater** units
- **ductless ventilation with heat recovery** ventilation units
- **rooftop products**, cooling, heating, ventilation units

We are constantly inspired by new technologies and improvements in terms of functionality, control and materials used. Simply put, we value good industrial design. Thanks to this for many years we have been creating new trends in the heating and ventilation industry. Our projects have been awarded in several prestigious international competitions in the field of industrial design, like The Red Dot Design Award, iF product design award and Dobry Wzrost, organized by Polish Institute of Industrial Design.



reddot award 2014  
winner



product  
design award



2014 ■



---

# TABLE OF CONTENTS

## Air heating and ventilation

■ LEO	8
■ LEO D	18
■ LEO EL	22
■ LEO EX	24
■ AGRO HT	28
■ AGRO SP/HP	32
■ AGRO ST	36

## Air curtains and air curtain-fan heater units

■ ELiS C	44
■ ELiS T	48
■ ELiS B	52
■ ELiS A	56
■ ELiS DUO	60
■ ELiS G	64

## Ductless ventilation with heat recovery

■ OXeN	72
--------	----

## Rooftop units

■ Cube	80
--------	----

# SYSTEM FLOWAIR

mini BMS at your finger tips

**T-box**  
intelligent controller  
with touch screen



**LEO BMS**  
fan heaters



**LEO KM**  
mixing chamber

## INTEGRATION OF DEVICES

SYSTEM FLOWAIR is an intelligent solution which integrates the devices into a system with only one controller. T-box offers many necessary functions for effective management of a heating-ventilating system. These function were previously reserved for an extensive Building Management System (BMS).



Control of devices with  
one T-box



Local regulation  
of devices



Advanced control of  
ventilating and heating  
devices



Control the devices  
according to your time  
schedule and individual  
needs



Antifreeze protects the  
devices against  
low temperatures

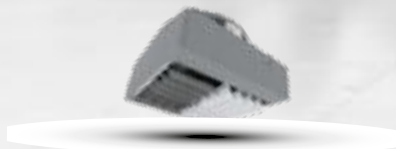

**LEO D BMS**  
destratificators



**ELiS**  
air curtains



**OXeN**  
ventilation unit with heat recovery



## **| SYNERGY OF DEVICES**

The system offers higher heat comfort and energy savings. Thanks to destratificators and fan heaters working together, it is possible to effectively use the hot air that is present under the ceiling, thus saving heat energy to be supplied by the fan heaters.





---

# AIR HEATING AND VENTILATION



# FAN HEATERS LEO



## Fan heaters **LEO**

Heating capacity [kW]	0,7–121
Air flow [m³/h]	1000–5800
Weight [kg]	9,5–26,2
Colour	grey
Casing	EPP expanded polypropylene

## APPLICATION

Big cubature buildings: industrial halls, warehouses, department stores, production halls, sports halls, sacral buildings, etc., as well as smaller rooms, like: workshops, garages, stores, car show rooms, gas stations, etc.

## AVAILABLE TYPES OF UNITS:

- LEO BMS**  
 LEO BMS fan heater is equipped with energy efficient 3 speed fans controlled by the DRV module. The DRV module manages the operation of devices according to control signals from T-box or directly from BMS.
- LEO**  
 LEO fan heater with AC fan offers possibility to switch between 3 steps of efficiency.

## DIMENSIONS

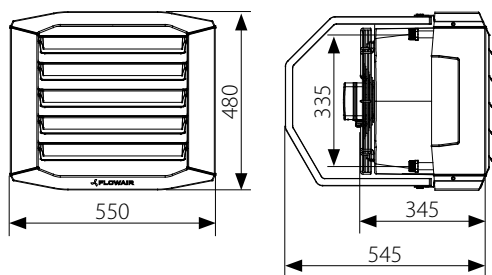

LEO S1 | S2 | S3 / LEO S1 BMS | S2 BMS | S3 BMS

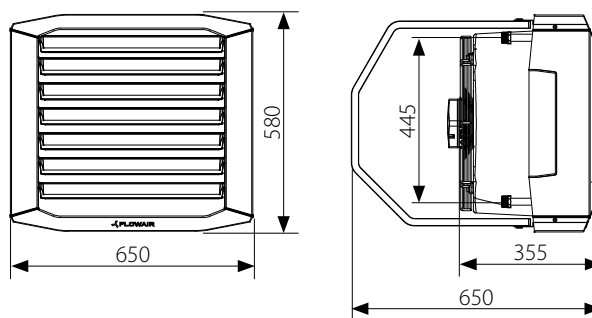

LEO L1 | L2 | L3 / LEO L1 BMS | L2 BMS | L3 BMS

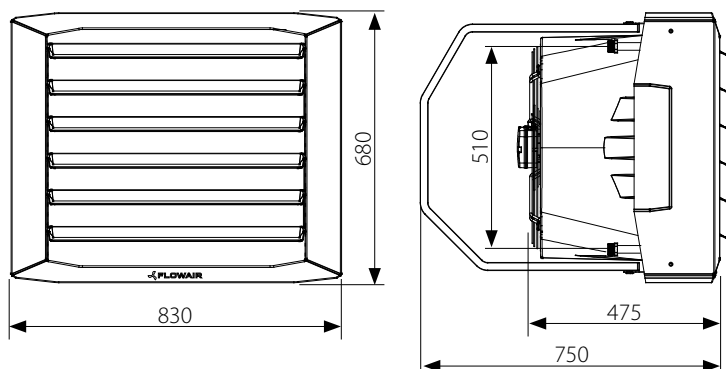

LEO XL2 | XL3 / LEO XL2 BMS | XL3 BMS

For CAD drawings, Revit files and documentation for all available versions of LEO visit [www.flowair.com](http://www.flowair.com)





# INSTALLATION

Possibility of setting the direction of air stream

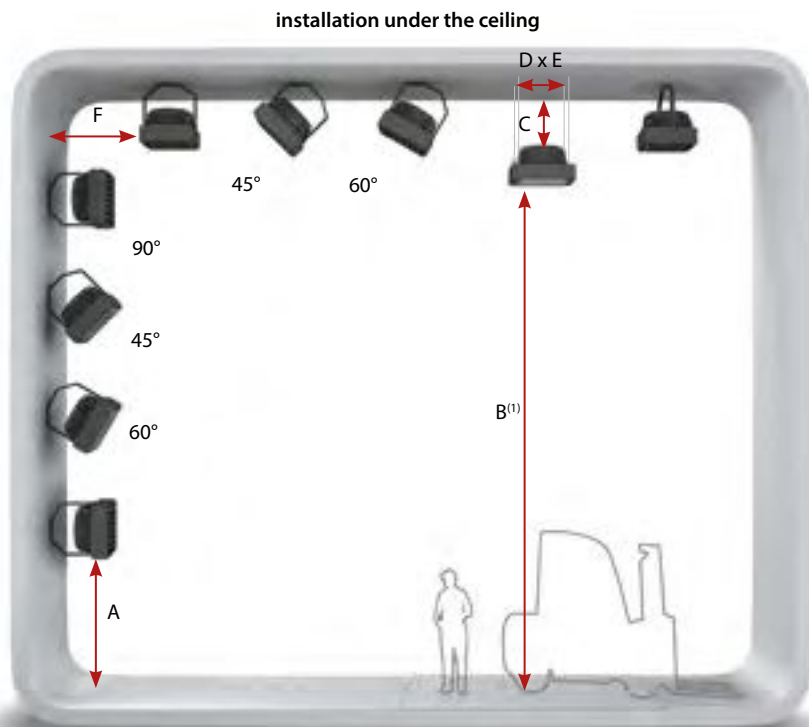

<sup>(1)</sup> When device is mounted under the ceiling please note the proper nonisothermal air stream range



**Optional corner brackets**  
For easy installation and leveling of the fan heater use optional corner mounting brackets.



**Rotary console**  
It enables installation of the heater perpendicularly or horizontally at various angles to the partition.

## I RECOMMENDED INSTALLATION DISTANCE [M]

	S1	S2	S3	L1	L2	L3	XL2	XL3
A	max. 3,0	max. 3,0	max. 3,0	2,5-8,0	2,5-8,0	2,5-8,0	2,5-8,0	2,5-8,0
B	2,5-7,0	2,5-6,0	2,5-6,0	2,5-9,5	2,5-8,5	2,5-8,0	2,5-9,5	2,5-9,0
C	min. 0,3							
D	0,415	0,415	0,415	0,515	0,515	0,515	0,66	0,66
E	0,415	0,415	0,415	0,515	0,515	0,515	0,58	0,58
F	min. 0,5							

## TECHNICAL DATA

### Fan heater LEO S

	LEO S1 / S1 BMS			LEO S2 / S2 BMS			LEO S3 / S3 BMS		
	III	II	I	III	II	I	III	II	I
Step	2300	1900	1500	2000	1600	1250	1800	1400	1000
Max. air flow stream [m <sup>3</sup> /h]	0,7 – 12,8			2,1 – 26,5			1,7 – 32,7		
Heating capacity [kW] <sup>(1)</sup>	4,5			10,2			12,3		
Nominal heat power (70/50/16°C, III-step) [kW]	230/50			230/50			230/50		
Power supply [V/Hz]	0,5	0,4	0,3	0,6	0,4	0,3	0,6	0,4	0,3
Max. current consumption [A]	120	90	70	130	90	70	130	90	70
Max. power consumption [W]	54/F			54/F			54/F		
IP / Insulation class	56,3	50,7	43,9	56,3	50,7	43,9	56,3	50,7	43,9
Max. acoustic pressure level [dB(A)] <sup>(2)</sup>	71,4	65,8	59,0	71,4	65,8	59,0	71,4	65,8	59,0
Max. acoustic power level [dB(A)] <sup>(3)</sup>	16,0	13,0	10,0	14,0	11,0	8,5	12,5	9,5	7,0
Horizontal range [m] <sup>(4)</sup>	6,0	5,1	4,1	5,3	4,4	3,5	4,9	3,9	2,9
Vertical range [m] <sup>(5)</sup>	120			120			120		
Max. heating water temperature [°C]	1,6			1,6			1,6		
Max. operating pressure [MPa]	½"			½"			½"		
Connection	60			60			60		
Max. operating temperature [°C]	9,5			10,4			10,8		
Weight of unit [kg]	10,2			11,6			12,2		
Weight of unit filled with water [kg]									

### Fan heater LEO L

	LEO L1 / LEO L1 BMS			LEO L2 / LEO L2 BMS			LEO L3 / LEO L3 BMS		
	III	II	I	III	II	I	III	II	I
Step	4250	2800	1700	3800	2400	1400	3400	2100	1200
Max. air flow stream [m <sup>3</sup> /h]	1,3 – 32,3			2,2 – 50,4			3,2 – 65,2		
Heating capacity [kW] <sup>(1)</sup>	11,7			19,1			25,6		
Nominal heat power (70/50/16°C, III-step) [kW]	230 /50			230/50			230/50		
Power supply [V/Hz]	1,4	1,2	0,6	1,5	1,2	0,6	1,5	1,2	0,6
Max. current consumption [A]	330	240	120	340	240	120	340	240	120
Max. power consumption [W]	54/F			54/F			54/F		
IP / Insulation class	64,1	54,5	42,1	64,1	54,5	42,1	64,1	54,5	42,1
Max. acoustic pressure level [dB(A)] <sup>(2)</sup>	79,2	69,6	57,2	79,2	69,6	57,2	79,2	69,6	57,2
Max. acoustic power level [dB(A)] <sup>(3)</sup>	24,0	15,0	9,5	21,5	13,0	8,0	19,0	11,5	6,5
Horizontal range [m] <sup>(4)</sup>	8,3	5,6	3,7	7,5	4,9	3,1	6,8	4,4	2,8
Vertical range [m] <sup>(5)</sup>	120			120			120		
Max. heating water temperature [°C]	1,6			1,6			1,6		
Max. operating pressure [MPa]	¾"			¾"			¾"		
Connection	60			60			60		
Max. operating temperature [°C]	14,9			16,2			17,8		
Weight of unit [kg]	15,9			18,2			20,5		
Weight of unit filled with water [kg]									

<sup>(1)</sup> The range of heating power with parameters below, min: 1<sup>st</sup> gear/speed of fan, temperature of heating medium 40/30°C, air temperature at the inlet 20°C, max. 3<sup>rd</sup> gear/speed of fan, temperature of heating medium 120/90°C, Air temperature at the inlet 0°C

<sup>(2)</sup> Acoustic pressure level at the distance of 5 m from the unit, in the room of medium capability of sound absorption and 1500 m<sup>3</sup> of cubature

<sup>(3)</sup> According to PN-EN ISO3744

<sup>(4)</sup> Range of horizontal isothermal air stream, at 0,5 m/s velocity limit

<sup>(5)</sup> Range of vertical nonisothermal air stream, at ΔT = 5°C at 0,5m/s velocity limit

## TECHNICAL DATA

### Fan heater **LEO XL**

Step	LEO XL2 / LEO XL2 BMS			LEO XL3 / LEO XL3 BMS		
	III	II	I	III	II	I
Max. air flow stream [m <sup>3</sup> /h]	5800	4600	2900	5300	4100	2500
Heating capacity [kW] <sup>(1)</sup>	6,6 – 94,0			8,3 – 121,0		
Nominal heat power (70/50/16°C, III-step) [kW]	36,5			48,1		
Power supply [V/Hz]	230/50			230/50		
Max. current consumption [A]	2,3	1,8	1,4	2,4	1,8	1,4
Max. power consumption [W]	520	370	270	550	370	270
IP / Insulation class	54/F			54/F		
Max. acoustic pressure level [dB(A)] <sup>(2)</sup>	67,5	61,1	52,3	67,5	61,1	52,3
Max. acoustic power level [dB(A)] <sup>(3)</sup>	82,6	76,2	67,8	82,6	76,2	67,8
Horizontal range [m] <sup>(4)</sup>	26,0	20,5	13,0	23,5	18,0	11,0
Vertical range [m] <sup>(5)</sup>	8,5	7,0	4,7	7,7	6,2	4,1
Max. heating water temperature [°C]	120			120		
Max. operating pressure [MPa]	1,6			1,6		
Connection	¾"			¾"		
Max. operating temperature [°C]	60			60		
Weight of unit [kg]	23,2			26,2		
Weight of unit filled with water [kg]	25,9			30,3		

<sup>(1)</sup> The range of heating power with parameters below, min: 1<sup>st</sup> gear/speed of fan, temperature of heating medium 40/30°C, air temperature at the inlet 20°C, max. 3<sup>rd</sup> gear/speed of fan, temperature of heating medium 120/90°C, Air temperature at the inlet 0°C

<sup>(2)</sup> Acoustic pressure level at the distance of 5 m from the unit, in the room of medium capability of sound absorption and 1500 m<sup>3</sup> of cubature

<sup>(3)</sup> According to PN-EN ISO3744

<sup>(4)</sup> Range of horizontal isothermal air stream, at 0,5 m/s velocity limit

<sup>(5)</sup> Range of vertical nonisothermal air stream, at  $\Delta T = 5^\circ\text{C}$  at 0,5m/s velocity limit

# ACCESSORIES – CONFUSOR LEO

for LEO L and XL fan heaters



Material: powder-painted steel, RAL 9007

Weight:

Confusor LEO L: 3,8 kg

Confusor LEO XL: 6,2 kg

Confusor increases air flow speed. It results in faster air distribution to the lower zones of the room.

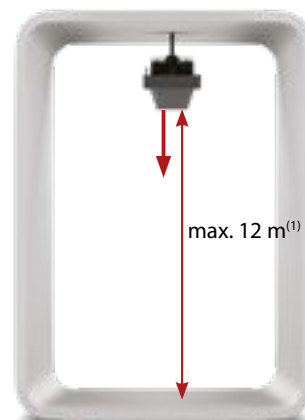

<sup>(1)</sup> When device is mounted under the ceiling please note the proper nonisothermal air stream range.

## DIMENSIONS

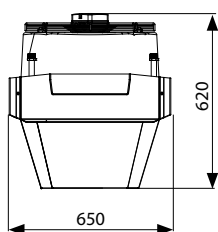

LEO L1 | L2 | L3 + L confusor

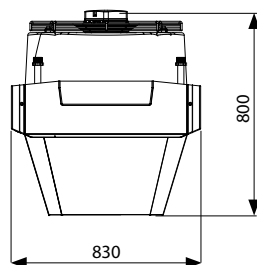

LEO XL2 | XL3 + XL confusor

# ACCESSORIES – 4-SIDE OUTLET GRILLE LEO

for LEO L and XL fan heaters



Material: powder-painted steel, RAL 9007

Weight:

Outlet grille LEO L: 2,8 kg

Outlet grille LEO XL: 4,8 kg

Outlet grille improves air distribution. It is perfect solution for low level ceiling rooms, where heaters are installed under the ceiling.

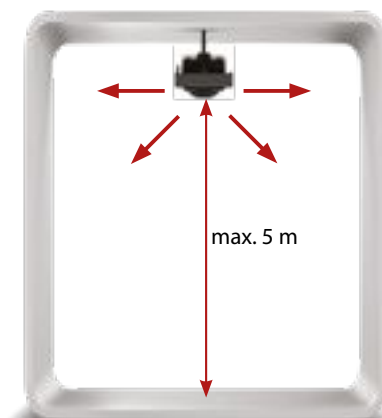

## DIMENSIONS

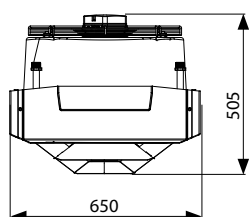

LEO L1 | L2 | L3 + L 4 side outlet grille

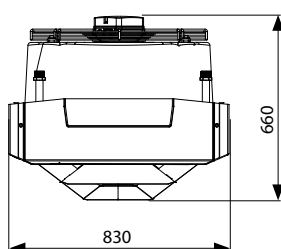

LEO XL2 | XL3 + XL 4 side outlet grille

# ACCESSORIES – MIXING CHAMBER

for all LEO fan heaters

LEO fan heaters with LEO KM mixing chamber from heating and ventilation unit. It is the easiest way to create efficient mechanical ventilation without additional systems.

## LEO + KM



## DIMENSIONS

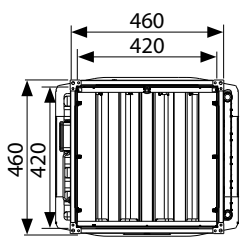

LEO S1 | S2 | S3 + KM S / LEO S1 BMS | S2 BMS | S3 BMS + KM S

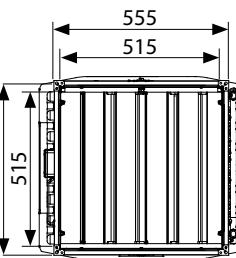
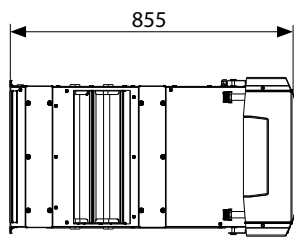

LEO L1 | L2 | L3 + KM L / LEO L1 BMS | L2 BMS | L3 BMS + KM L

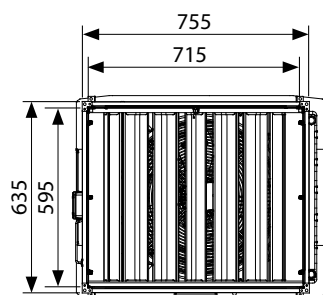
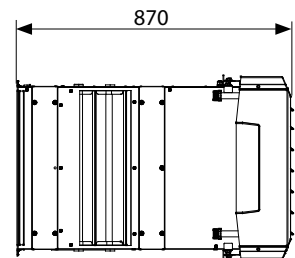

LEO XL2 | XL3 + KM XL / LEO XL2 BMS | XL3 BMS + KM XL

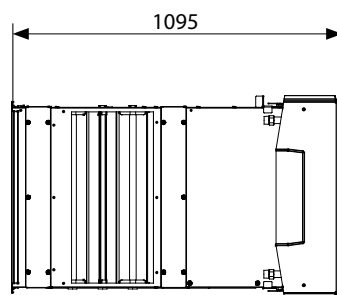

For CAD drawings, Revit files and documentation for all available versions of LEO visit [www.flowair.com](http://www.flowair.com)



# CONTROL SYSTEMS

for LEO heaters LEO / LEO BMS



## TS CONTROLLER basic version

Simplest regulation of 3-step fans. Fan heater operation is controlled by 3-step fan speed controller with thermostat.



## HMI CONTROLLER basic version

Advanced regulation of 3-step fans via HMI programmable controller.



## T-box CONTROLLER BMS version

Intelligent regulation system of 3-step fans. Speed regulation of energy-efficient fan via T-box controller.

## FAN HEATER LEO



TS Controller



HMI Controller



T-box Controller

### Types of regulation/control

Manual 3-step air flow regulation

✓

✓

✓

Automatic 3-step air flow regulation

✓

✓

### Modes

Heating / Ventilation

✓

✓

✓

Operation in continuous or thermostatic mode

✓

✓

✓

Weekly programmer

✓

✓

BMS

✓

✓

Antifreeze

✓

✓

Integration with FLOWAIR SYSTEM

✓

### Max. number of connected units

Via controller

7

5

31

Via additional splitters

36

36

n/d

# CONNECTION DIAGRAMS

## TS / HMI CONTROLLER

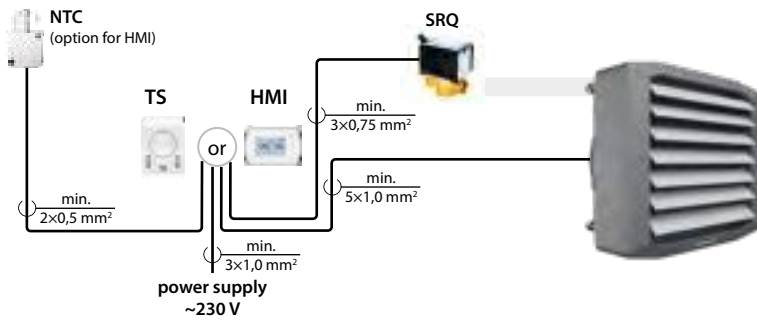

### to 1 TS controller:

- max. 7 units LEO S
- max. 3 units LEO L
- max. 2 units LEO XL

### to 1 HMI controller:

- max. 5 units LEO S
- max. 2 units LEO L
- max. 1 units LEO XL

It is possible to apply RX splitters to increase the maximum number of controlled units

## T-box CONTROLLER

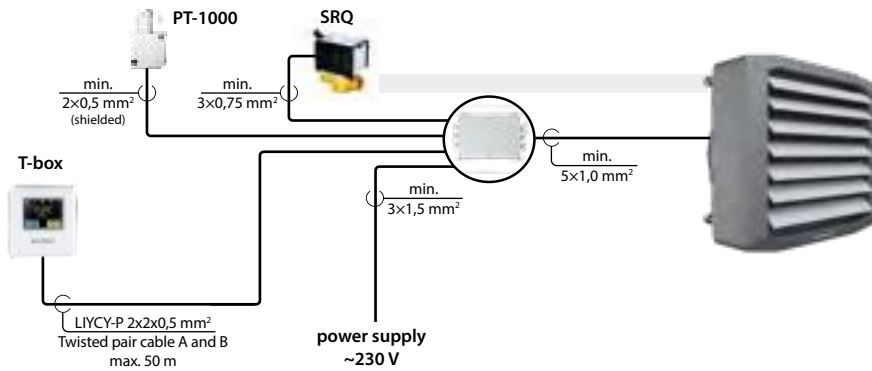

**max. 31 units compatible**  
with FLOWAIR SYSTEM  
to 1 T-box controller

# HEATING CAPACITIES

Tw1/Tw2 = 120/90°C					Tw1/Tw2 = 90/70°C					Tw1/Tw2 = 70/50°C					Tw1/Tw2 = 60/40°C					Tw1/Tw2 = 40/30°C				
Tp1	PT	Qw	Δpw	Tp2	Tp1	PT	Qw	Δpw	Tp2	Tp1	PT	Qw	Δpw	Tp2	Tp1	PT	Qw	Δpw	Tp2	Tp1	PT	Qw	Δpw	Tp2
°C	kW	l/h	kPa	°C	°C	kW	l/h	kPa	°C	°C	kW	l/h	kPa	°C	°C	kW	l/h	kPa	°C	°C	kW	l/h	kPa	°C
LEO S1 / LEO S1 BMS																								
V = 2300 m³/h																								
0,0	12,8	381	1,8	16,5	0,0	9,8	430	2,4	12,5	0,0	6,7	292	1,3	8,5	0,0	5,0	219	0,8	6,5	0,0	3,8	325	1,7	5,0
5,0	12,2	362	1,6	20,5	5,0	9,1	401	2,1	16,5	5,0	6,0	262	1,0	12,5	5,0	4,3	188	0,6	10,5	5,0	3,0	263	1,2	9,0
10,0	11,5	343	1,5	24,5	10,0	8,4	372	1,8	21,0	10,0	5,3	232	0,8	17,0	10,0	3,6	155	0,4	14,5	10,0	2,3	197	0,7	13,0
15,0	10,9	324	1,3	29,0	15,0	7,8	343	1,6	25,0	15,0	4,6	202	0,7	21,0	15,0	2,7	117	0,3	18,5	15,0	1,2	104	0,2	16,5
20,0	10,2	305	1,2	33,0	20,0	7,1	314	1,3	29,0	20,0	3,9	170	0,5	25,0	20,0	1,7	74	0,1	22,0	20,0	0,8	72	0,1	21,0
LEO S2 / LEO S2 BMS																								
V = 2000 m³/h																								
0,0	26,5	788	10,7	39,0	0,0	20,1	889	14,2	30,0	0,0	14,4	631	8,2	21,5	0,0	11,5	502	5,6	17,0	0,0	8,3	719	11,4	12,5
5,0	25,2	750	9,8	42,0	5,0	18,9	832	12,6	33,0	5,0	13,1	574	6,9	24,5	5,0	10,2	445	4,5	20,0	5,0	7,0	604	8,4	15,5
10,0	24,0	713	8,9	45,0	10,0	17,6	776	11,1	36,0	10,0	11,8	517	5,7	27,5	10,0	8,9	386	3,6	23,0	10,0	5,6	488	5,8	18,5
15,0	22,7	676	8,1	48,0	15,0	16,3	719	9,7	39,0	15,0	10,5	459	4,6	30,5	15,0	7,5	328	2,7	26,0	15,0	4,3	370	3,5	21,0
20,0	21,5	639	7,3	51,0	20,0	15,0	663	8,4	42,0	20,0	9,2	401	3,6	33,5	20,0	6,1	267	1,9	29,0	20,0	2,8	246	1,7	24,0
LEO S3 / LEO S3 BMS																								
V = 1800 m³/h																								
0,0	32,7	973	8,4	54,0	0,0	24,9	1098	11,1	41,0	0,0	17,6	769	6,2	29,0	0,0	13,8	603	4,2	23,0	0,0	10,1	872	8,6	16,5
5,0	31,1	925	7,6	56,0	5,0	23,3	1026	9,8	43,0	5,0	15,9	697	5,2	31,0	5,0	12,2	530	3,3	25,0	5,0	8,4	726	6,2	18,5
10,0	29,5	878	6,9	58,0	10,0	21,6	954	8,6	45,5	10,0	14,3	624	4,3	33,5	10,0	10,5	457	2,5	27,0	10,0	6,7	579	4,1	21,0
15,0	27,9	831	6,3	60,5	15,0	20,0	883	7,5	47,5	15,0	12,6	551	3,4	35,5	15,0	8,8	382	1,8	29,0	15,0	4,9	428	2,4	23,0
20,0	26,3	784	5,6	62,5	20,0	18,4	811	6,4	49,5	20,0	10,9	478	2,6	37,5	20,0	7,0	304	1,2	31,5	20,0	3,1	264	1,0	25,0
LEO L1 / LEO L1 BMS																								
V = 4250 m³/h																								
0,0	32,3	961	7,0	22,5	0,0	24,6	1086	9,4	17,0	0,0	17,1	749	5,1	12,0	0,0	13,3	578	3,3	9,0	0,0	9,8	845	7,0	7,0
5,0	30,7	913	6,4	26,5	5,0	23,0	1014	8,3	21,0	5,0	15,4	676	4,2	15,5	5,0	11,6	504	2,6	13,0	5,0	8,0	697	4,9	10,5
10,0	29,1	865	5,8	30,0	10,0	21,3	941	7,2	25,0	10,0	13,8	602	3,4	19,5	10,0	9,8	429	1,9	17,0	10,0	6,3	547	3,2	14,5
15,0	27,5	818	5,2	34,0	15,0	19,7	869	6,3	28,5	15,0	12,1	528	2,7	23,5	15,0	8,1	352	1,4	20,5	15,0	4,5	391	1,8	18,0
20,0	25,9	770	4,7	37,5	20,0	18,0	796	5,3	32,5	20,0	10,4	453	2,1	27,0	20,0	6,2	272	0,9	24,5	20,0	1,6	139	0,3	21,0

V – air flow  
PT – heating capacity  
Tp1 – inlet air temperature

Tp2 – outlet air temperature  
Tw1 – inlet water temperature  
Tw2 – outlet water temperature

Qw – water flow in the heat exchanger  
Δpw – water pressure drop in the heat exchanger



# HEATING CAPACITIES

Tw1/Tw2 = 120/90°C					Tw1/Tw2 = 90/70°C					Tw1/Tw2 = 70/50°C					Tw1/Tw2 = 60/40°C					Tw1/Tw2 = 40/30°C				
Tp1	PT	Qw	Δpw	Tp2	Tp1	PT	Qw	Δpw	Tp2	Tp1	PT	Qw	Δpw	Tp2	Tp1	PT	Qw	Δpw	Tp2	Tp1	PT	Qw	Δpw	Tp2
°C	kW	l/h	kPa	°C	°C	kW	l/h	kPa	°C	°C	kW	l/h	kPa	°C	°C	kW	l/h	kPa	°C	°C	kW	l/h	kPa	°C
LEO L2 / LEO L2 BMS																								
V = 3800 m³/h																								
0,0	50,4	1 500	7,9	43,5	0,0	38,4	1693	10,5	33,0	0,0	27,2	1190	5,9	23,5	0,0	21,5	937	4,0	18,5	0,0	15,6	1 351	8,2	13,5
5,0	48,0	1 428	7,2	46,5	5,0	35,9	1584	9,3	36,0	5,0	24,7	1079	4,9	26,5	5,0	18,9	825	3,2	21,5	5,0	13,0	1 128	5,9	16,0
10,0	45,5	1 355	6,5	49,0	10,0	33,4	1474	8,1	38,5	10,0	22,1	968	4,1	29,0	10,0	16,3	712	2,4	24,0	10,0	10,4	902	4,0	19,0
15,0	43,1	1 283	5,9	52,0	15,0	30,9	1364	7,1	41,5	15,0	19,6	856	3,3	31,5	15,0	13,7	598	1,8	26,5	15,0	7,7	671	2,4	21,5
20,0	40,7	1 211	5,3	54,5	20,0	28,4	1254	6,1	44,0	20,0	17,0	743	2,5	34,5	20,0	11,0	480	1,2	29,5	20,0	4,9	425	1,1	24,0
LEO L3 / LEO L3 BMS																								
V = 3400 m³/h																								
0,0	65,2	1 942	11,9	63,0	0,0	49,4	2182	15,7	48,0	0,0	35,7	1564	9,1	34,5	0,0	28,8	1254	6,4	28,0	0,0	20,5	1 775	12,6	20,0
5,0	62,2	1 852	10,9	65,0	5,0	46,4	2046	13,9	49,5	5,0	32,6	1426	7,7	36,5	5,0	25,6	1115	5,2	29,5	5,0	17,3	1 499	9,3	21,5
10,0	59,2	1 762	10,0	67,0	10,0	43,3	1910	12,3	51,5	10,0	29,5	1289	6,4	38,5	10,0	22,4	975	4,1	31,5	10,0	14,1	1 220	6,5	23,5
15,0	56,2	1 672	9,1	68,5	15,0	40,2	1775	10,8	53,5	15,0	26,3	1150	5,3	40,0	15,0	19,1	832	3,1	33,5	15,0	10,8	935	4,0	25,5
20,0	53,2	1 584	8,2	70,5	20,0	37,1	1639	9,3	55,0	20,0	23,1	1010	4,2	42,0	20,0	15,8	686	2,2	35,0	20,0	7,3	637	2,1	27,0
LEO XL2 / LEO XL2 BMS																								
V = 5800 m³/h																								
0,0	94,0	2 799	23,1	52,5	0,0	71,6	3159	30,7	40,0	0,0	51,4	2248	17,5	28,5	0,0	41,2	1794	12,1	23,0	0,0	29,6	2 568	24,4	16,5
5,0	89,5	2 666	21,1	54,5	5,0	67,0	2958	27,2	42,0	5,0	46,8	2046	14,7	31,0	5,0	36,5	1591	9,7	25,5	5,0	24,9	2 161	17,9	19,0
10,0	85,1	2 533	19,2	57,0	10,0	62,5	2757	23,9	44,5	10,0	42,1	1843	12,2	33,5	10,0	31,8	1386	7,6	27,5	10,0	20,2	1 751	12,3	21,0
15,0	80,6	2 400	17,4	59,5	15,0	57,9	2556	20,8	47,0	15,0	37,5	1639	9,9	35,5	15,0	27,1	1179	5,7	30,0	15,0	15,4	1 336	7,6	23,5
20,0	76,2	2 269	15,7	61,5	20,0	53,4	2355	17,9	49,0	20,0	32,8	1433	7,8	38,0	20,0	22,2	969	4,0	32,0	20,0	10,5	910	3,8	25,5
LEO XL3 / LEO XL3 BMS																								
V = 5300 m³/h																								
0,0	121,0	3 602	18,7	74,0	0,0	91,6	4043	24,6	56,0	0,0	66,6	2916	14,4	41,0	0,0	54,0	2352	10,2	33,0	0,0	38,2	3 313	20,0	23,5
5,0	115,4	3 436	17,2	75,5	5,0	86,0	3794	21,9	57,5	5,0	60,9	2664	12,3	42,0	5,0	48,1	2097	8,3	34,5	5,0	32,4	2 807	14,9	25,0
10,0	109,9	3 270	15,7	76,5	10,0	80,3	3545	19,4	59,0	10,0	55,1	2411	10,2	43,5	10,0	42,2	1840	6,5	35,5	10,0	26,5	2 297	10,4	26,0
15,0	104,3	3 106	14,3	78,0	15,0	74,7	3296	17,0	60,0	15,0	49,3	2157	8,4	45,0	15,0	36,2	1580	5,0	37,0	15,0	20,5	1 777	6,6	27,5
20,0	98,9	2 944	12,9	79,5	20,0	69,1	3048	14,7	61,5	20,0	43,4	1900	6,7	46,0	20,0	30,1	1314	3,6	38,0	20,0	14,3	1 238	3,5	28,5

V – air flow  
 PT – heating capacity  
 Tp1 – inlet air temperature

Tp2 – outlet air temperature  
 Tw1 – inlet water temperature  
 Tw2 – outlet water temperature

Qw – water flow in the heat exchanger  
 Δpw – water pressure drop in the heat exchanger

# DESTRATIFICATORS LEO D

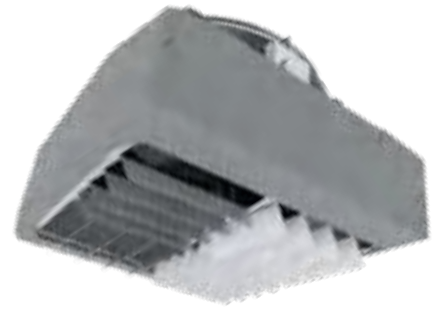

## Destratifiers **LEO D**

Air flow [m <sup>3</sup> /h]	2500–7200
Weight [kg]	8,9–19,5
Colour	grey
Casing	EPP expanded polypropylene

## APPLICATION

Destratifiers are dedicated to be used inside buildings. They work together with other devices in the heating system. They increase the efficiency of heating of large and high spaces for example production facilities, warehouses, supermarkets and trade fair centers.

## AVAILABLE TYPES OF UNITS:

- **LEO D BMS**  
version with a DRV-D module with a temperature sensor, integration with FLOWAIR SYSTEM
- **LEO D**  
without additional regulation
- **LEO DT**  
with mounted thermostat

## TECHNICAL DATA

### Destratifiers **LEO D**

Step	LEO D S / D S BMS / D T S			LEO D L / D L BMS / D T L			LEO D XL		
	III	II	I	III	II	I	III	II	I
Max. range of air stream [m <sup>3</sup> /h]	2500	2200	1900	5200	4200	2800	7200	6100	3900
Power supply [V/Hz]	230/50			230/50			230/50		
Max. current consumption [A]	0,5	0,4	0,3	1,3	1,0	0,6	2,0	1,5	1,3
Max. power consumption [W]	110	80	70	280	200	120	450	350	260
IP / Insulation class	54/F			54/F			54/F		
Max. acoustic pressure level [dB(A)] <sup>(1)</sup>	56,9	55,2	49,4	65,7	58,4	44,9	72,8	66,9	53,7
Max. acoustic power level [dB(A)] <sup>(2)</sup>	72,0	70,3	64,9	80,8	73,5	60,4	87,9	82,0	69,2
Maks. operating temperature [°C]	60			60			60		
Position of operation	horizontal			horizontal			horizontal		
Weight of unit [kg]	8,9			13,9			19,5		

<sup>(1)</sup> Acoustic pressure level at the distance of 5 m from the unit, in the room of medium capability of sound absorption and 1500 m<sup>3</sup> of cubature

<sup>(2)</sup> According to PN-EN ISO3744

# INSTALLATION

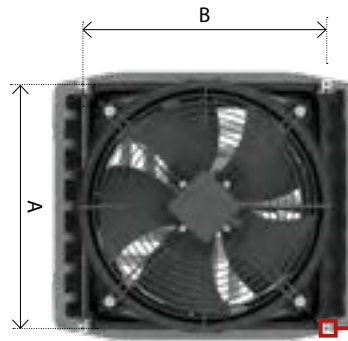

	LEO D S	LEO D L	LEO D XL
A	415	515	585
B	415	515	665



The destratificator is equipped with corner holders, which make the installation and leveling of the unit under the ceiling much easier. In case of installation under the ceiling which transmit vibrations it is recommended to use vibro-isolators.

## DIMENSIONS

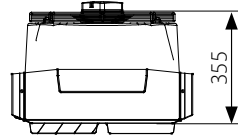
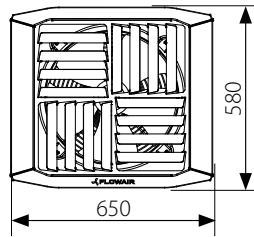
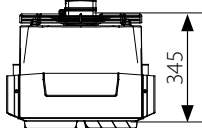
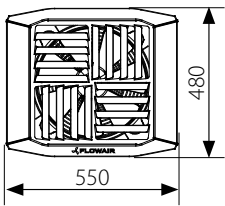

LEO D S BMS | LEO DT S | LEO D S

LEO D L BMS | LEO DT L | LEO D L

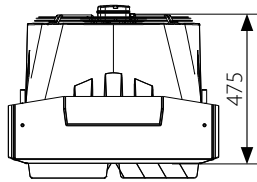
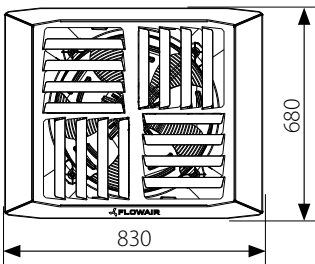

LEO D XL BMS | LEO DT XL | LEO D XL

For CAD drawings, Revit files and documentation for all available versions of LEO visit [www.flowair.com](http://www.flowair.com)



## FUNCTION OF DESTRATIFICATOR

Destratificator prevents accumulation of the warm air in the upper zones of the room. The fan redirects the warm air back into the zone occupied by the people. It limits heat losses and heat transfer through the roof. This results in faster heating of a building.



# CHOOSE AN OPTIMAL DESTRATIFICATOR

LEO D destratificator assists the proper operation of heating system counteracting the accumulation of warm air in the upper zones of the room. 3 sizes of destratificators make it possible to choose the perfect fit for the different heights of the building. A wide range of air flow efficiency 1900-7200 m<sup>3</sup>/h ensures high user comfort in rooms with a low and high level of ceiling.

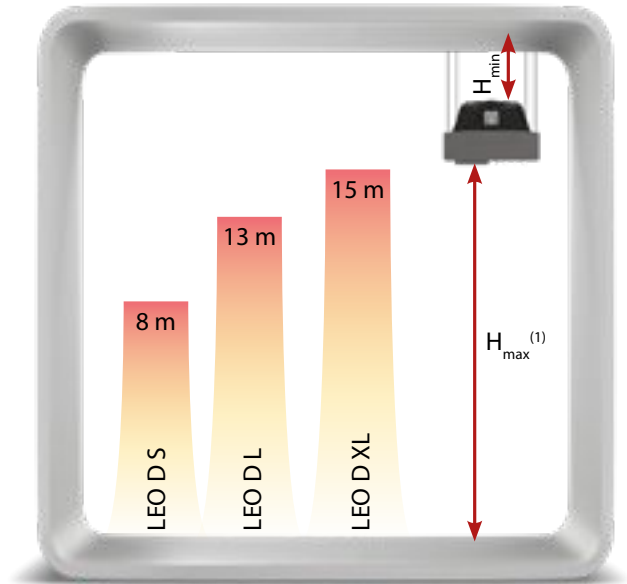

<sup>(1)</sup> When device is mounted under the ceiling please note the proper nonisothermal air stream range

# AUTOMATIC DESTRATIFICATION SYSTEM

## AUTOMATIC DESTRATIFICATION:

It offers energy savings thanks to the redirection of warm air from the upper zone to the lower zone of the room. The destratificators switch on when the temperature drops in the room and there is an excess of warm air under the ceiling. If this heat is not sufficient the LEO heaters switch on.

- **Step 1** – activation of destratificators to push down the warm air from the area under the ceiling.
- **Step 2** – activation of fan heaters in order to reach the temp level set by the user.



# CONNECTION DIAGRAMS

## SYNERGY OF DEVICES WHEN CONNECTED TO FLOWAIR SYSTEM

max. 31 units  
compatible with FLOWAIR SYSTEM  
to 1 T-box controller

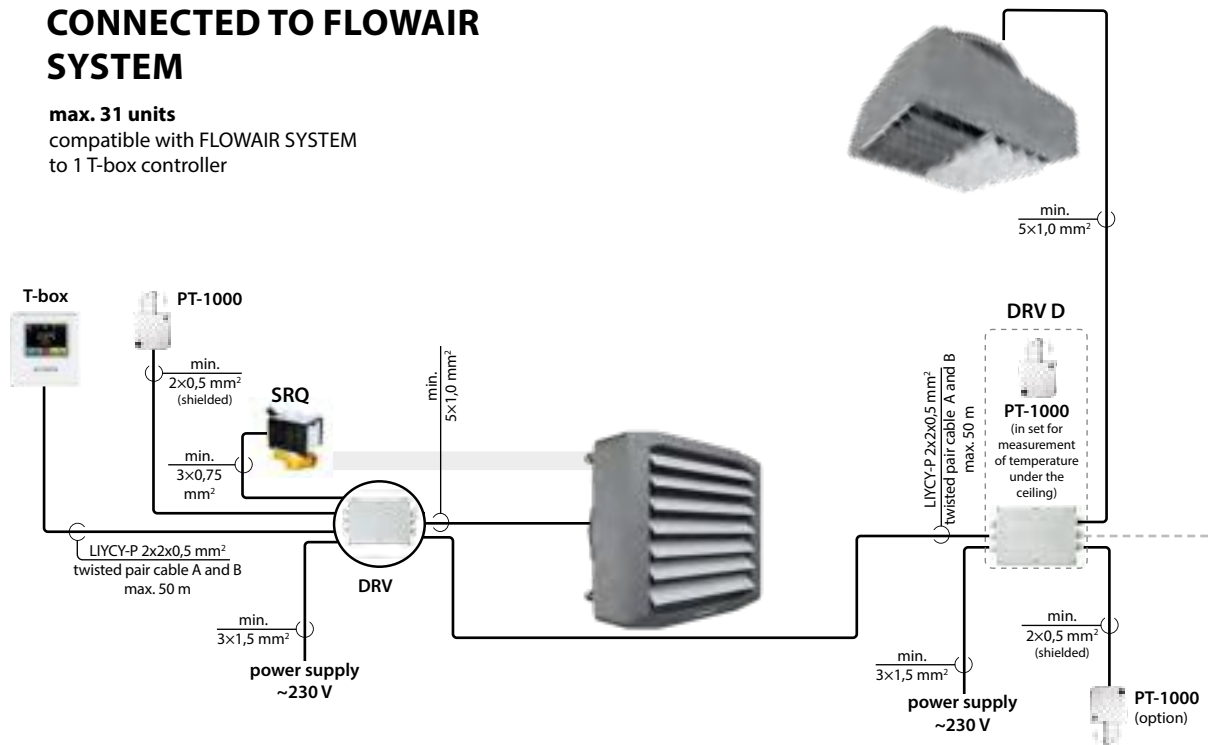

### ELEMENTS:

- **T-box**  
intelligent controller with touch screen
- **PT-1000**  
wall-mounted temperature sensor
- **SRQ**  
valve with actuator

## LEO D BMS REGULATION WITH T-box CONTROLLER

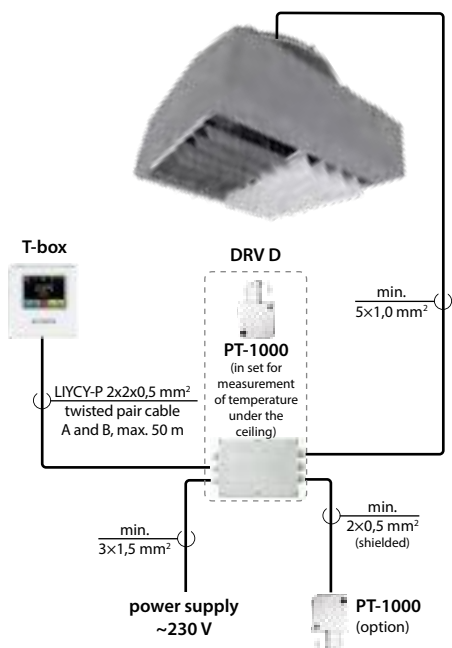

## LEO DT ON/OFF MODE

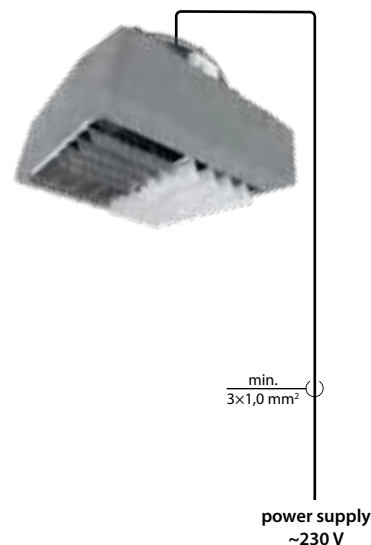

# ELECTRIC HEATERS

## LEO EL



### Electric heaters **LEO EL**

Heating capacity [kW]	5,3–22,8
Air flow [m³/h]	1250–4250
Weight [kg]	19,7/27,8
Colour	grey
Casing	steel

### APPLICATION

Objects of any cubic capacity: production halls, warehouses, stadiums, depots, shopping pavilions, workshops, garages and production facilities.

### CHARACTERISTIC

LEO EL – electric fan heaters are designed for operating indoors. They are used where there is no access to another source of heat such as a gas or hot water powered system.

### DIMENSIONS

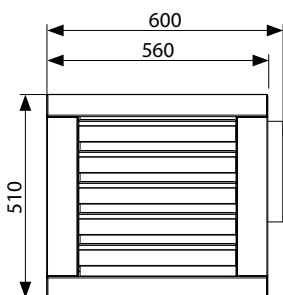

**LEO EL S BMS**

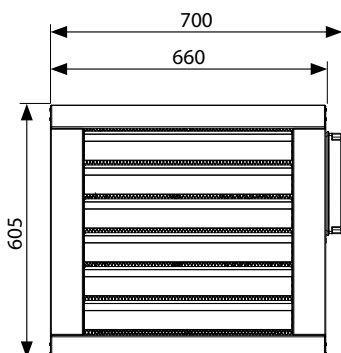
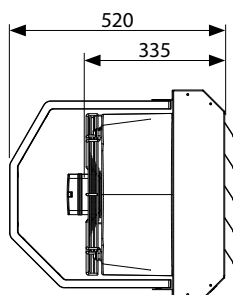

**LEO EL L BMS**

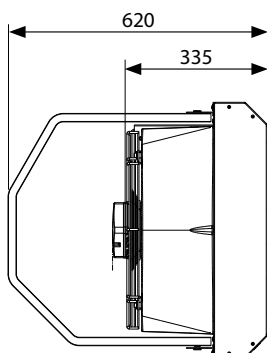

For CAD drawings, Revit files and documentation for all available versions of LEO visit [www.flowair.com](http://www.flowair.com)



## TECHNICAL DATA

### Electric heaters LEO EL

	LEO EL S BMS	LEO EL L BMS
Fan	3 speed fan, Axial, single-phase, AC	3 speed fan, Axial, single-phase, AC
Heating capacity <sup>(1)</sup> [kW]	6,0 / 10,8	8,8 / 16,3 / 22,8
Max. air flow stream [m <sup>3</sup> /h]	2000	4250
Power supply [V/Hz]	3×400	3×400
Current consumption [A]	15,6	33,3
IP / Protection degree	20	20
Max. acoustic pressure level <sup>(2)</sup> [dB(A)]	56,3	64,1
Max. range of air stream <sup>(3)</sup> [m]	14	24,0
Max. operating temperature [°C]	50	50
Weight of unit [kg]	19,7	27,8

<sup>(1)</sup> At inlet air temperature 0°C, max. air volume

<sup>(2)</sup> Acoustic pressure level measured in the room with average sound absorption, capacity 1500 m<sup>3</sup>, at distance of 5 m from the unit

<sup>(3)</sup> Horizontal range of isothermal stream, at 0,5 m/s velocity limit

## INSTALLATION

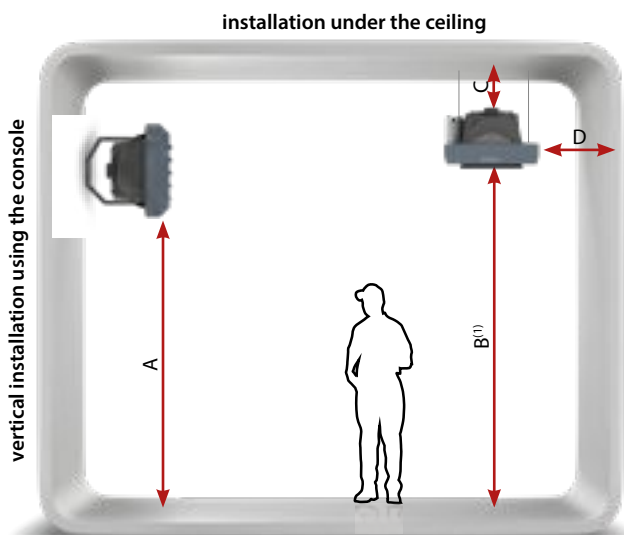

### Rotary console

It enables vertical installation of the heater on the wall. It also makes it possible to rotate the unit 170° around the connection points with console.

### INSTALLATION DISTANCE

	EL S BMS	EL L BMS
<b>A [m]</b>	max. 3,0	max. 6,0
<b>B [m]</b>	max. 6,0	max. 9,5
<b>C [m]</b>	max. 0,2	max. 0,2
<b>D [m]</b>	max. 0,5	max. 0,5

<sup>(1)</sup> When device is mounted under the ceiling please note the proper nonisothermal air stream range

## CONNECTION DIAGRAM

### T-box CONTROLLER

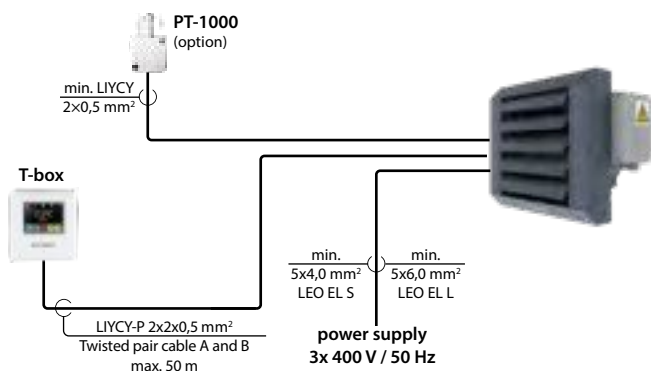

**max. 31 units compatible**  
with FLOWAIR SYSTEM  
to 1 T-box controller

# FAN HEATERS

## LEO EX



### Fan heaters **LEO EX**

Heating capacity [kW]	3,0–57,3
Air flow [m <sup>3</sup> /h]	3600–4000
Weight [kg]	33,1–34,5
Colour	grey
Casing	powder-painted steel

## APPLICATION

Buildings with special safety requirements, like heavy industry halls, welding plants etc.

## CHARACTERISTIC

Fan heaters equipped with anti-explosion fan and may be installed in Z-2 explosion-risk zones, in rooms at risk of explosion of gases, liquids and their fumes from IIA and IIB group of explosiveness and T3 temperature class.

## DIMENSIONS

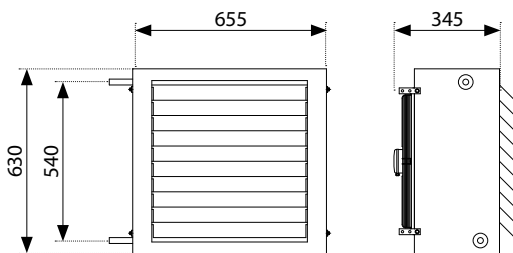

LEO EX

For CAD drawings, Revit files and documentation for all available versions of LEO visit [www.flowair.com](http://www.flowair.com)





## TECHNICAL DATA

### Fan heaters LEO EX

	LEO EX L1	LEO EX L2
Max. air flow [m <sup>3</sup> /h]	4000	3600
Heating capacity [kW]	3,0 – 32,4	6,1 – 57,3
Nominal heating capacity (70/50/16°C)	12,1	22,1
Power supply [V/Hz]	Y - 3x400/50	Y - 3x400/50
Max. current consumption [A]	Y - 0,51	Y - 0,51
Max. power consumption [W]	Y - 290	Y - 290
IP / Insulation class	44 / F	44 / F
Sound pressure level [dB(A)] <sup>(1)</sup>	59,5	59,5
Sound power level [dB(A)] <sup>(2)</sup>	75	75
Isometric horizontal range [m] <sup>(3)</sup>	21	19
Nonisothermal vertical range [m] <sup>(4)</sup>	7,4	6,7
Max. heating water temperature [°C]	130	130
Max. operating pressure [Mpa]	1,6	1,6
Connection ["]	¾	¾
Type of casing	powder-painted steel	powder-painted steel
Color	grey	grey
Usage	inside buildings	inside buildings
Maximum operational temperature [°C]	40	40
Position of operation	horizontal or vertical	horizontal or vertical
Weight of unit [kg]	33,1	34,5
Weight of unit filled with water [kg]	34,2	36,6

<sup>(1)</sup> Acoustic pressure level at a distance of 5 m from the unit, in the room of medium capability of sound absorption and 1500 m<sup>3</sup> of cubic measure

<sup>(2)</sup> According to PN-EN ISO3744

<sup>(3)</sup> Range of horizontal, isothermal air stream at 0,5 m/s speed limits

<sup>(4)</sup> Range of vertical nonisothermal air stream, at  $\Delta T = 5^{\circ}\text{C}$  at 0,5m/s velocity limit

The range of heating power with parameters below:

– min: temperature of heating medium 40/30°C, air temperature at the inlet 20°C

– max: temperature of heating medium 120/90°C, Air temperature at the inlet 0°C

## INSTALLATION

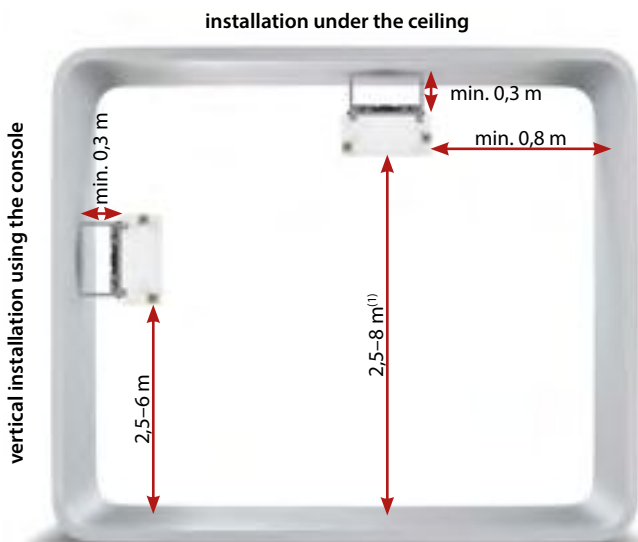

### EX brackets

Enable easy and quick installation of the unit on the wall or under the ceiling.

<sup>(1)</sup> When device is mounted under the ceiling please note the proper nonisothermal air stream range

# CONNECTION DIAGRAM

Explosion-proof automation, available in two versions:

- **EX LITE** – power and control cabinet designed to work outside the EX zone, the cabinet includes all the necessary protections to control the motor located in the EX zone
- **EX PLUS** – power and control cabinet designed for operation outside the EX zone, includes thermostat (ATEX), the cabinet includes all the necessary protections to control the motor located in the EX zone, thermostat intended for operation in the zone (ATEX), weekly programmer.

Each version (LITE/PLUS) can be expanded and control several devices from one place.

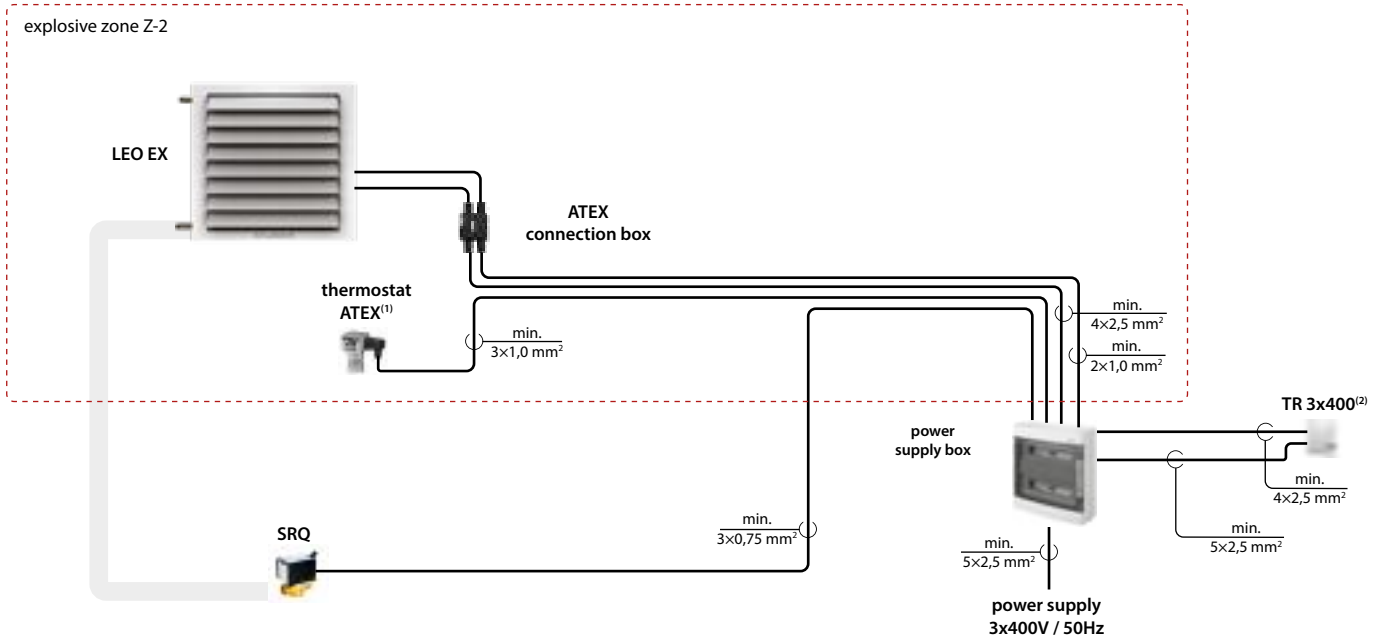

<sup>(1)</sup> in EX-PLUS set

<sup>(2)</sup> option



## Z-2 ZONES

All components installed in the hazardous area are approved according to ATEX directive, allowing operation in 2G zone.

# HEATING CAPACITIES

Tw1/Tw2 = 90/70°C					Tw1/Tw2 = 80/60°C					Tw1/Tw2 = 70/50°C					Tw1/Tw2 = 60/40°C				
Tp1	PT	Qw	Δpw	Tp2	Tp1	PT	Qw	Δpw	Tp2	Tp1	PT	Qw	Δpw	Tp2	Tp1	PT	Qw	Δpw	Tp2
°C	kW	l/h	kPa	°C	°C	kW	l/h	kPa	°C	°C	kW	l/h	kPa	°C	°C	kW	l/h	kPa	°C
LEO EX L1																			
V = 4000 m <sup>3</sup> /h																			
0	24,7	1 088	10,7	18,5	0	21	924	8,2	15,5	0	17,4	761	5,9	13	0	13,7	596	4	10
5	23,1	1 018	9,5	22	5	19,4	854	7,1	19,5	5	15,8	690	5	16,5	5	12	524	3,2	14
10	21,5	947	8,3	26	10	17,8	783	6,1	23	10	14,1	618	4,1	20,5	10	10,3	451	2,4	17,5
15	19,9	876	7,2	29,5	15	16,2	711	5,1	27	15	12,5	545	3,3	24	15	8,6	376	1,8	21,5
20	18,3	805	6,2	33,5	20	14,6	639	4,2	30,5	20	10,8	472	2,5	28	20	6,9	299	1,2	25
LEO EX L2																			
V = 3600 m <sup>3</sup> /h																			
0	43,6	1 923	15,4	36	0	37,4	1 643	11,9	31	0	31,2	1 364	8,8	25,5	0	24,9	1 085	6,1	20,5
5	40,8	1 801	13,7	38,5	5	34,6	1 520	10,4	33,5	5	28,4	1 240	7,4	28,5	5	22	960	4,9	23
10	38	1 678	12	41	10	31,8	1 397	8,9	36	10	25,5	1 116	6,1	31	10	19,1	834	3,8	25,5
15	35,2	1 555	10,5	43,5	15	29	1 273	7,5	38,5	15	22,7	992	5	33,5	15	16,2	707	2,8	28
20	32,5	1 433	9	46	20	26,2	1 149	6,3	41	20	19,8	866	3,9	36	20	13,2	577	2	30,5

To obtain operating parameters concerning other water temperatures please contact Sales Office.

V – air flow

PT – heating capacity

Tp1 – inlet air temperature

Tp2 – outlet air temperature

Tw1 – inlet water temperature

Tw2 – outlet water temperature

Qw – water flow in the heat exchanger

Δpw – water pressure drop in the heat exchanger

# FAN HEATERS AGRO HT

## Fan heaters **AGRO HT**

Air flow [m <sup>3</sup> /h]	10 000
Weight [kg]	76,0 – 88,0
Colour	red-black
Casing	plastic



## APPLICATION

Big cubature buildings with considerable pollution of the air with solid particles, high humidity or corrosive environment. Dedicated to chicken farms, piggeries.

## CHARACTERISTIC

Fan heaters in plastic casing with long heating range and with heat exchanger protected by anti-corrosive coating.

## DIMENSIONS

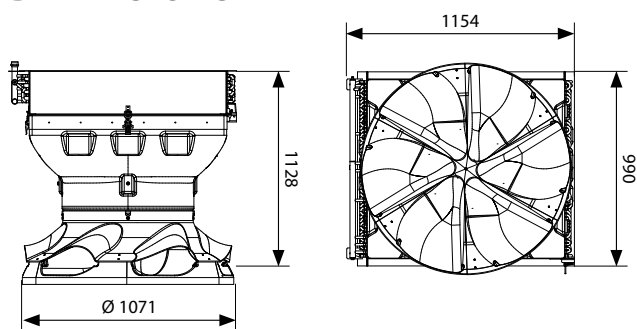

For CAD drawings, Revit files and documentation for all available versions of LEO visit [www.flowair.com](http://www.flowair.com)



## TECHNICAL DATA

### Fan heaters **AGRO HT**

	AGRO HT 50	AGRO HT 75
Air flow [m <sup>3</sup> /h]	10 000	10 000
Power supply [V/Hz]	3x400/50	3x400/50
Max. current consumption [A]	1,4	1,4
Max. power consumption [W]	560	560
Max. acoustic pressure level <sup>(1)</sup> [dB(A)]	66	66
Max. air stream range <sup>(2)</sup> [m]	54	54
Max. heating water temperature [°C]	95	95
Max. operating pressure [MPa]	1,6	1,6
Connection	1"	1"
Weight of unit [kg]	76	88
Weight of unit filled with water [kg]	86	104

<sup>(1)</sup> Acoustic pressure level at the distance of 5 m from the unit, in the room of medium capability of sound absorption and 1500 m<sup>3</sup> of cubature

<sup>(2)</sup> Range of horizontal isothermal air stream, at 0,5 m/s velocity limit

# CONTROL SYSTEM

## CONTROL SYSTEM OF AGRO HT

R55 thermostat controls valve through SZS AGRO HT.

### FEATURES OF SZS AGRO HT:

- change the direction of rotation of the fan (L/R),
- on/off regulation,
- operation / Malfunction indication,
- control of succession of asymmetry and phase loss.

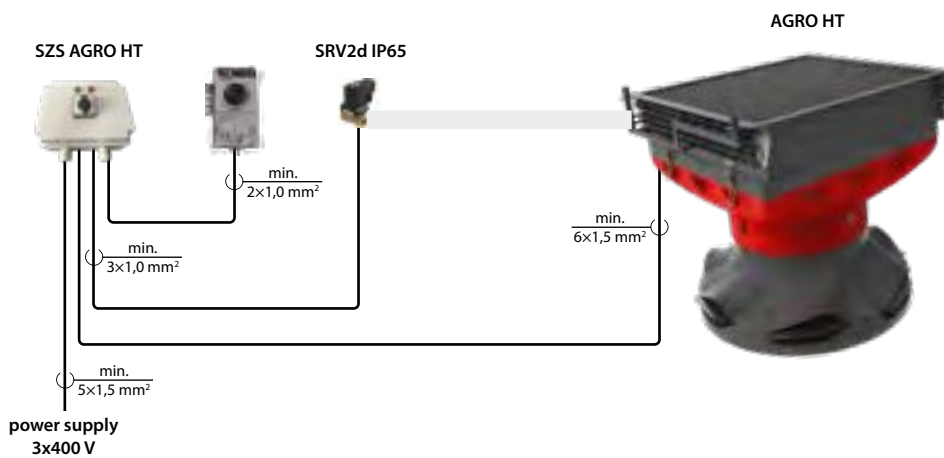

# INSTALLATION

installation under the ceiling<sup>(1)</sup>

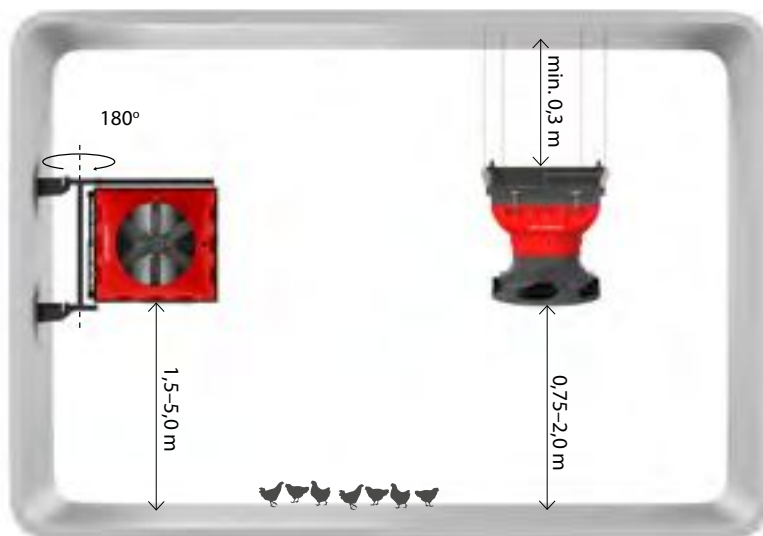

vertical installation using the console



### Rotary console AGRO HT

Rotary consoles enables 180° rotation of the device which lets you direct the air stream in any direction. Additionally, the console ensures easy access to the unit from any side.

<sup>(1)</sup> Installation under the ceiling of AGRO HT with air outlet

# ACCESSORIES



## AGRO HT 6-SIDE AIR OUTLET

Material: plastic  
Weight: 8,6 kg

AGRO HT 6-side air outlet distributes the air when heater is installed under the ceiling

### Benefits of using AGRO HT 6-side air outlet:

- steady temperature distribution,
- better quality of bedding,
- lower concentration of ammonia,
- lower level of humidity in the room.

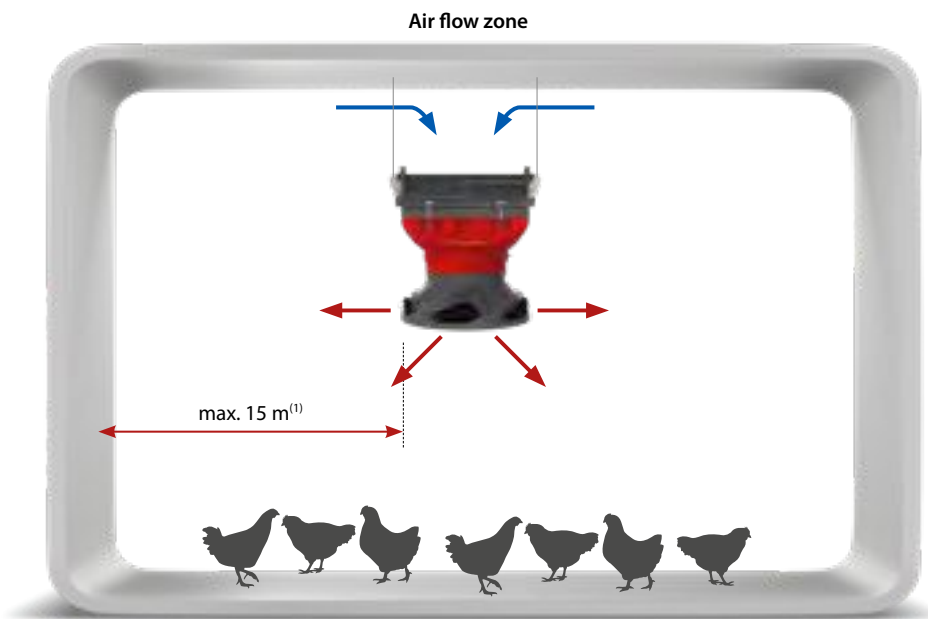

<sup>(1)</sup> Range of horizontal isothermal air stream, at 0,5 m/s velocity limit



## SPECIAL PROTECTION

Heat exchanger is protected by special anti-corrosion coating, resistant to e.g ammonia.  
Additional units are equipped with dustproof and water-proof IP66 fan.

# HEATING CAPACITIES

Tw1 / Tw2 = 90/70°C					Tw1 / Tw2 = 80/60°C					Tw1 / Tw2 = 70/50°C					Tw1 / Tw2 = 60/40°C					Tw1 / Tw2 = 50/40°C				
Tp1	PT	Qw	Δpw	Tp2	Tp1	PT	Qw	Δpw	Tp2	Tp1	PT	Qw	Δpw	Tp2	Tp1	PT	Qw	Δpw	Tp2	Tp1	PT	Qw	Δpw	Tp2
[°C]	[kW]	[l/h]	[kPa]	[°C]	[°C]	[kW]	[l/h]	[kPa]	[°C]	[°C]	[kW]	[l/h]	[kPa]	[°C]	[°C]	[kW]	[l/h]	[kPa]	[°C]	[°C]	[kW]	[l/h]	[kPa]	[°C]
AGRO HT 75 = 10 000 m³/h																								
0	170	7515	138	47,2	0	149	6510	110	41,1	0	127	5517	83,4	35	0	105	4534	60	28,9	0	94,7	8200	180	26,2
5	158	6962	120	49,5	5	136	5971	93,5	43,4	5	115	4992	69,3	37,3	5	92,7	4021	48,2	31,1	5	83,1	7195	142	28,4
10	146	6421	104	51,8	10	124	5444	79	45,6	10	103	4478	56,9	39,5	10	81,1	3518	37,8	33,3	10	71,8	6212	109	30,6
15	134	5892	88,6	54	15	112	4929	65,9	47,8	15	91,2	3974	45,8	41,6	15	69,7	3024	28,7	35,3	15	60,7	5253	79,8	32,7
20	122	5375	74,9	56,2	20	101	4424	54	49,9	20	79,8	3489	35,9	43,7	20	58,4	2535	20,8	37,3	20	49,8	4311	55,6	34,8
25	110	4868	62,5	58,3	25	89,6	3929	43,5	52	25	68,7	2994	27,3	45,7	25	47,2	2050	14,1	39,2	25	39,1	3384	35,7	36,8
30	99,1	4371	51,3	60,4	30	78,5	3442	34,2	54,1	30	57,6	2513	19,8	47,7	30	35,9	1559	8,5	41	30	28,5	2464	20	38,7
35	88,1	3883	41,3	62,4	35	67,6	2963	26	56	35	46,7	2035	13,5	49,5	35	24	1041	4,1	42,5	35	17,7	1530	8,4	40,5
AGRO HT 50 = 10 000m³/h																								
0	116	5099	46,9	32	0	100	4394	36,7	27,8	0	84,8	3699	27,5	23,5	0	69,4	3010	19,4	19,2	0	64,2	5556	60,6	17,8
5	107	4722	40,7	35,2	5	91,9	4027	31,2	30,9	5	76,6	3340	22,8	26,6	5	61,3	2660	15,4	22,3	5	56,2	4865	47,5	20,8
10	98,7	4352	35	38,3	10	83,7	3667	26,3	34	10	68,5	2988	18,6	29,7	10	53,4	2316	12	25,3	10	48,4	4189	36,1	23,9
15	90,5	3990	29,8	41,4	15	75,6	3313	21,8	37,1	15	60,6	2643	14,8	32,7	15	45,6	1977	9	28,3	15	40,7	3525	26,3	26,9
20	82,4	3634	25,1	44,5	20	67,7	2966	17,8	40,1	20	52,8	2303	11,5	35,7	20	37,8	1642	6,4	31,2	20	33,2	2873	18	29,8
25	74,5	3285	20,9	47,5	25	59,9	2625	14,2	43,1	25	45,2	1969	8,6	38,6	25	30,2	1309	4,2	34,1	25	25,8	2232	11,3	32,8
30	66,7	2942	17	50,5	30	52,2	2289	11,1	46	30	37,6	1638	6,2	41,5	30	22,5	974	2,5	36,9	30	18,4	1596	6,2	35,6
35	59,1	2605	13,6	53,4	35	44,7	1958	8,3	48,9	35	30	1308	4,1	44,3	35	14,4	623	1,1	39,5	35	11	953	2,4	38,4

To obtain operating parameters concerning other water temperatures please contact Sales Office.

V – air flow  
 PT – heating capacity  
 Tp1 – inlet air temperature

Tp2 – outlet air temperature  
 Tw1 – inlet water temperature  
 Tw2 – outlet water temperature

Qw – water flow in the heat exchanger  
 Δpw – water pressure drop in the heat exchanger

# FAN HEATERS AGRO SP/HP

## Fan heaters **AGRO SP/HP**

Heating capacity [kW]	8,7–56,2
Air flow [m <sup>3</sup> /h]	3300–4600
Weight [kg]	27,3/31,0
Colour	grey
Casing	plastic



## APPLICATION

Medium and big cubature buildings with considerable pollution of the air with solid particles, high humidity or corrosive environment.

## CHARACTERISTIC

- **AGRO SP**  
Fan heater with epoxidized heat exchanger. Dedicated to chicken farms.
- **AGRO HP**  
Fan heater with epoxidized heat exchanger protected by anti-corrosive coating. Dedicated to piggeries.

## DIMENSIONS

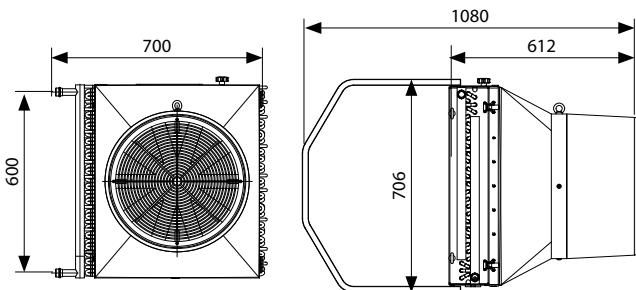

■ For CAD drawings, Revit files and documentation for all available versions of LEO visit [www.flowair.com](http://www.flowair.com)



## TECHNICAL DATA

### Fan heaters **AGRO SP/HP**

### **AGRO SP/HP**

Air flow [m <sup>3</sup> /h]	4600
Power supply [V/Hz]	230/50
Max. current consumption [A]	2,5
Max. power consumption [W]	360
Max. acoustic pressure level <sup>(1)</sup> [dB(A)]	62
Max. air stream range <sup>(2)</sup> [m]	28
Max. heating water temperature [°C]	95
Max. operating pressure [MPa]	1,6
Weight of unit [kg]	27,3
Weight of unit filled with water [kg]	31,0

<sup>(1)</sup> Acoustic pressure level at the distance of 5 m from the unit, in the room of medium capability of sound absorption and 1500 m<sup>3</sup> of cubature

<sup>(2)</sup> Range of horizontal isothermal air stream, at 0,5 m/s velocity limit



# CONTROL SYSTEM

## CONTROL SYSTEM OF AGRO SP/HP

### Features:

- low thermal inertia,
- low investment costs,
- easy to use,
- independent regulation of every single unit,
- gradual regulation of air flow.

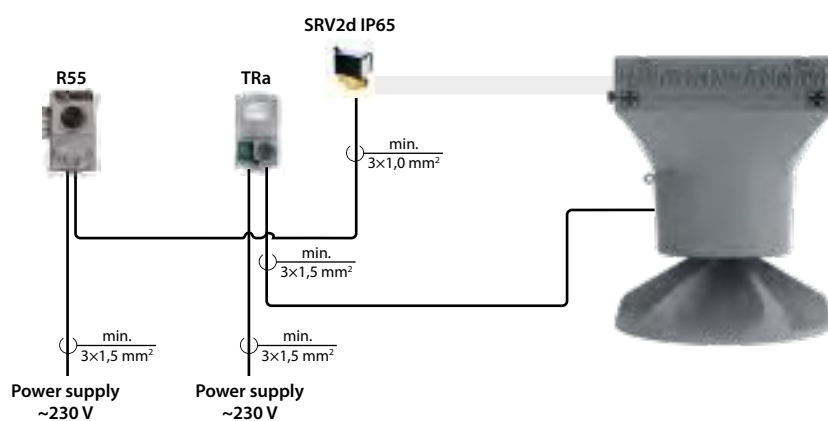

- R55 thermostat controls SRV2d IP65 valve
- TRa enables 5-step fan speed regulation

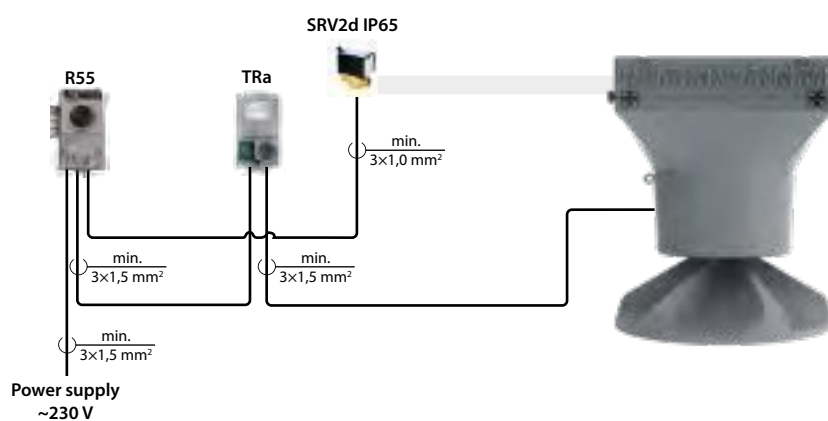

- R55 thermostat controls SRV2d IP65 valve and TRa regulator
- TRa enables 5-step fan speed regulation

---

# INSTALLATION

installation under the ceiling<sup>(1)</sup>

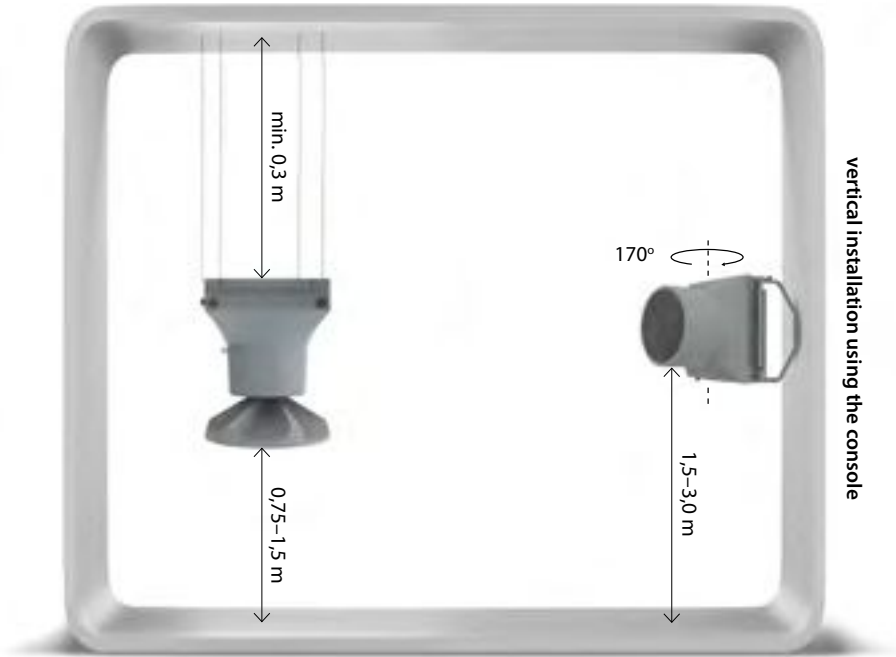

vertical installation using the console

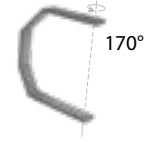

**Rotary console**  
AGRO SP/HP

For wall-mounting, a rotary console is available. Rotary consoles enables 170° rotation of the device which lets you direct the air stream in any direction. Additionally, the console ensures easy access to the unit from any side.

<sup>(1)</sup> Installation under the ceiling of AGRO SP/HP with air outlet.

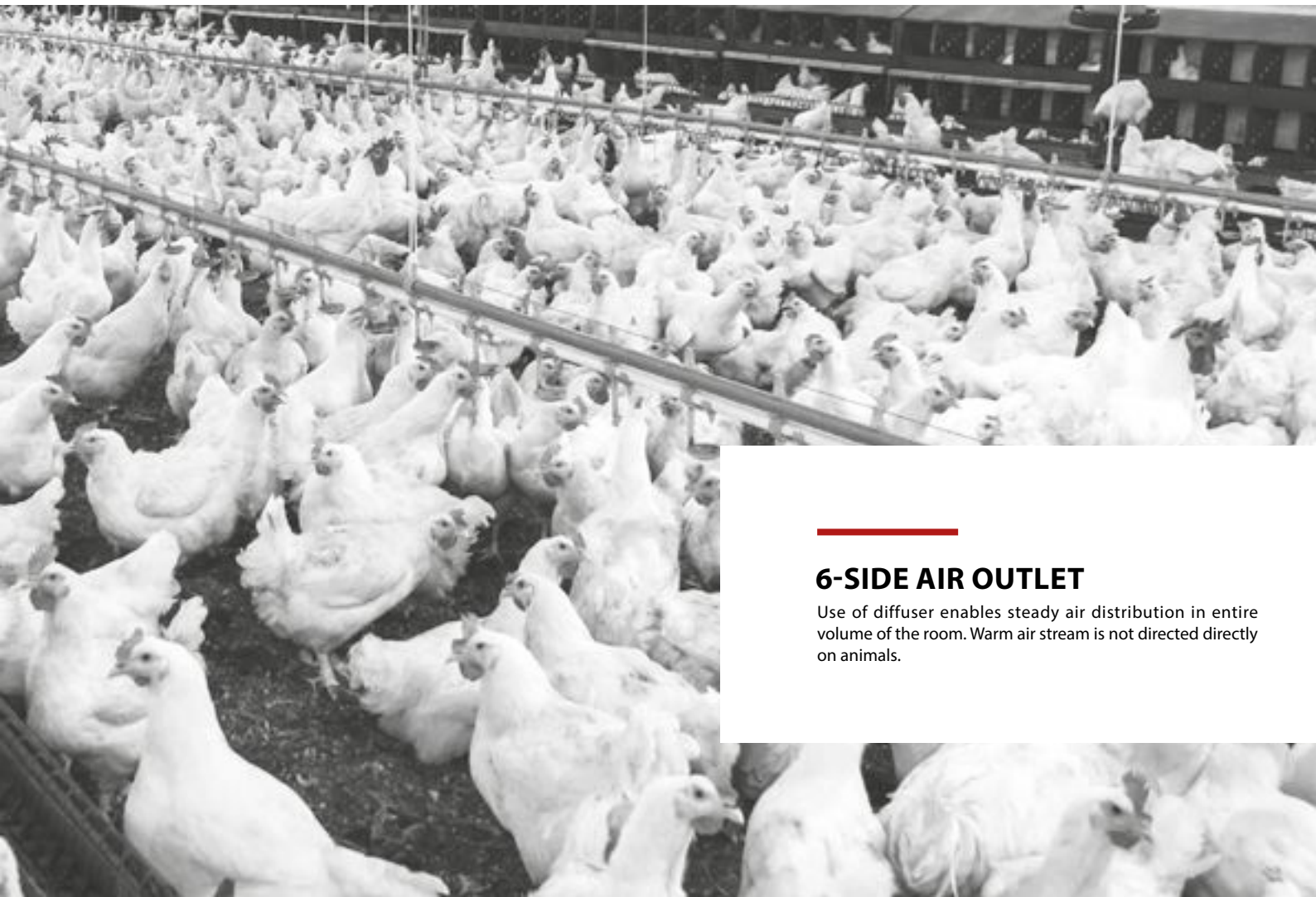

---

## 6-SIDE AIR OUTLET

Use of diffuser enables steady air distribution in entire volume of the room. Warm air stream is not directed directly on animals.

# ACCESSORIES



## AGRO SP/HP 6-SIDE AIR OUTLET

Material: plastic  
Weight: 1,6 kg

AGRO SP 6-side air outlet distributes the air when heater is installed under the ceiling.

### Benefits of using AGRO SP 6-side air outlet:

- steady temperature distribution,
- better quality of bedding,
- lower concentration of ammonia,
- lower level of humidity in the room.

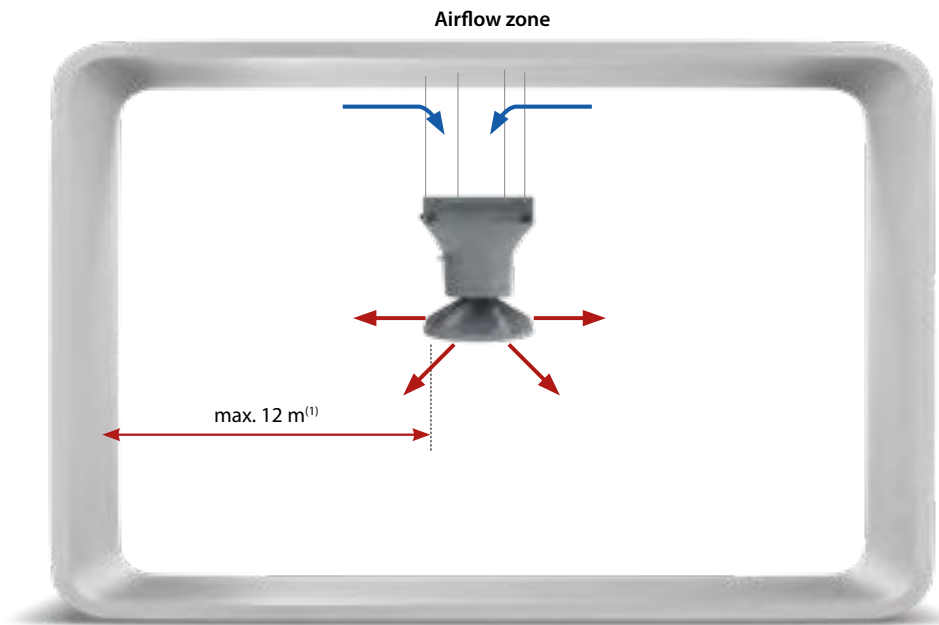

<sup>(1)</sup> Range of horizontal isothermal air stream, at 0,5 m/s velocity limit.

# HEATING CAPACITIES

Tw1 / Tw2 = 90/70°C					Tw1 / Tw2 = 80/60°C					Tw1 / Tw2 = 70/50°C					Tw1 / Tw2 = 60/40°C					Tw1 / Tw2 = 50/40°C				
Tp1	PT	Qw	Δpw	Tp2	Tp1	PT	Qw	Δpw	Tp2	Tp1	PT	Qw	Δpw	Tp2	Tp1	PT	Qw	Δpw	Tp2	Tp1	PT	Qw	Δpw	Tp2
[°C]	[kW]	[l/h]	[kPa]	[°C]	[°C]	[kW]	[l/h]	[kPa]	[°C]	[°C]	[kW]	[l/h]	[kPa]	[°C]	[°C]	[kW]	[l/h]	[kPa]	[°C]	[°C]	[kW]	[l/h]	[kPa]	[°C]
AGRO SP/HP = 4600 m <sup>3</sup> /h																								
0	56,2	2480	21	34	0	48,6	2140	16	29,5	0	41	1800	12	25	0	33,4	1450	10	20,5	0	31,2	2710	26	19
5	52	2290	18	37	5	44,5	1950	14	32,5	5	36,9	1620	10	28	5	29,4	1280	8	23	5	27,2	2370	21	22
10	47,8	2110	16	40	10	40,4	1780	12	35,5	10	33	1440	10	31	10	25,5	1110	8	26	10	23,4	2030	16	24,5
15	43,8	1930	13	43	15	36,4	1600	10	38,5	15	29,1	1270	8	33,5	15	21,6	940	6	29	15	19,6	1710	12	27,5
20	39,8	1750	11	46	20	32,6	1430	10	41	20	25,3	1110	8	36,5	20	17,9	780	4	31,5	20	15,9	1380	10	30,5
25	35,9	1580	9	49	25	28,7	1260	8	44	25	21,5	940	6	39,5	25	14,1	610	4	34,5	25	12,3	1070	7	33
30	32,1	1420	9	51,5	30	25	1100	7	47	30	17,8	780	4	42	30	10,3	450	4	37	30	8,7	750	6	36
35	28,4	1250	7	54,5	35	21,3	940	5	49,5	35	14,1	620	4	44,5	35	6,4	280	2	39,5	35	5	440	4	38,5

To obtain operating parameters concerning other water temperatures please contact Sales Office.

V – air flow

PT – heating capacity

Tp1 – inlet air temperature

Tp2 – outlet air temperature

Tw1 – inlet water temperature

Tw2 – outlet water temperature

Qw – water flow in the heat exchanger

Δpw – water pressure drop in the heat exchanger

# FAN HEATER AGRO ST

## Fan heater **AGRO ST**

Heating capacity [kW]	6,6–43
Air flow [m <sup>3</sup> /h]	1900–3700
Weight [kg]	21,8–23,9
Colour	grey
Casing	powder-painted steel



## APPLICATION

Medium and big cubature buildings with considerable pollution of the air with solid particles, high humidity or corrosive environment. Dedicated to chicken farms.

## CHARACTERISTIC

Fan heater with epoxidized heat exchanger in casing made of galvanized steel protected by anti-corrosive coating.

## DIMENSIONS

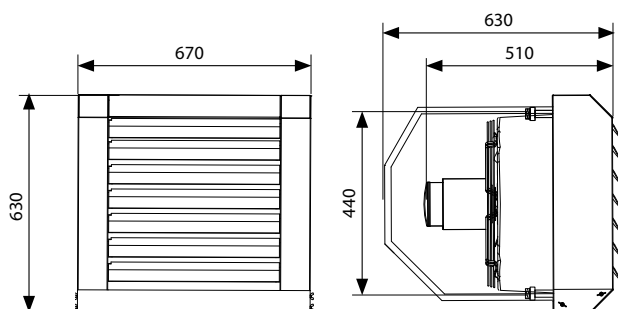

For CAD drawings, Revit files and documentation for all available versions of LEO visit [www.flowair.com](http://www.flowair.com)



## TECHNICAL DATA

### Fan heater **AGRO ST**

### AGRO ST

Air flow [m <sup>3</sup> /h]	3700
Power supply [V/Hz]	230/50
Max. current consumption [A]	1,8
Max. power consumption [W]	350
Max. acoustic pressure level <sup>(1)</sup> [dB(A)]	51
Max. air stream range <sup>(2)</sup> [m]	22
Max. heating water temperature [°C]	130
Max. operating pressure [MPa]	1,6
Weight of unit [kg]	21,8
Weight of unit filled with water [kg]	23,9

<sup>(1)</sup> Acoustic pressure level at the distance of 5 m from the unit, in the room of medium capability of sound absorption and 1500 m<sup>3</sup> of cubature

<sup>(2)</sup> Range of horizontal isothermal air stream, at 0,5 m/s velocity limit

# CONTROL SYSTEM

## CONTROL SYSTEM OF AGRO ST

### Features:

- low thermal inertia,
- low investment costs,
- easy to use,
- independent regulation of every single unit,
- gradual regulation of air flow.

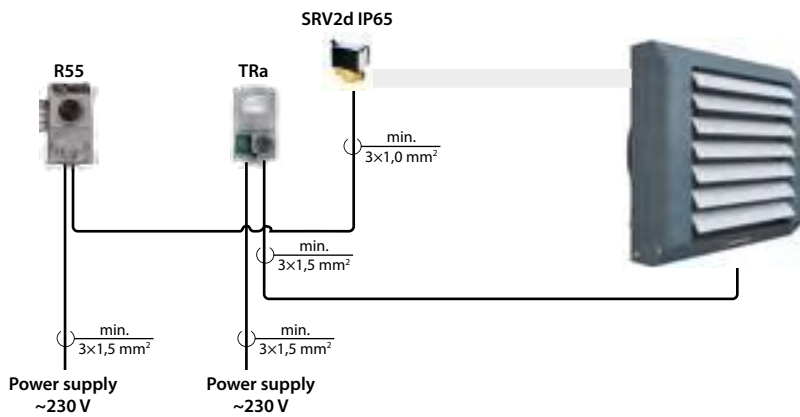

- R55 thermostat controls SRV2d IP65 valve
- TRa enables 5-step fan speed regulation

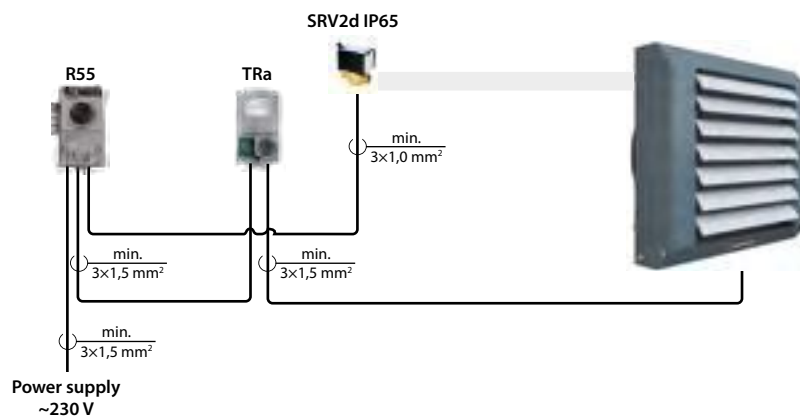

- R55 thermostat controls SRV2d IP65 valve and TRa regulator
- TRa enables 5-step fan speed regulation

---

# INSTALLATION

vertical installation using the console

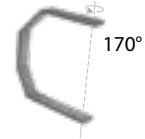
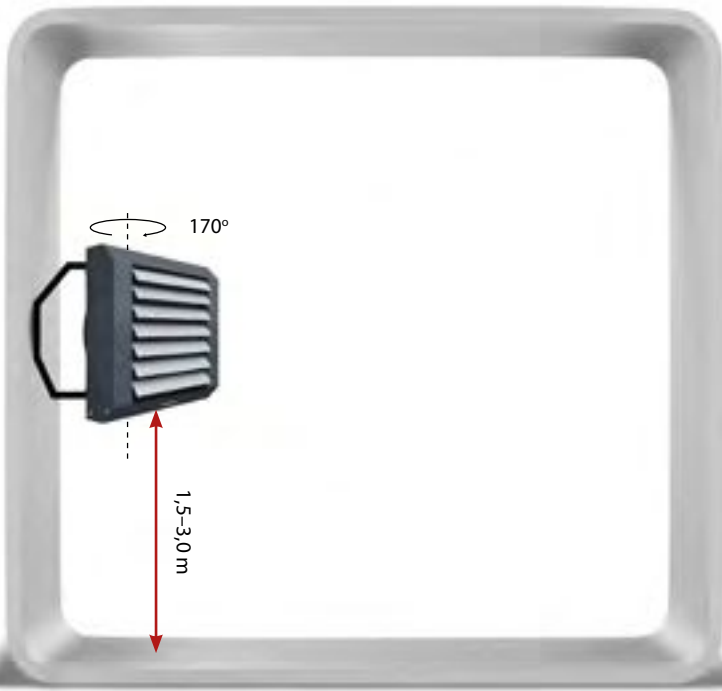

## Rotary console AGRO ST

Rotary consoles enables 170° rotation of the device which lets you direct the air stream in any direction. Additionally, the console ensures easy access to the unit from any side.



---

## EASY CLEANING

Easy access to unit's interior makes the maintenance and service operations faster. Hinged construction and blocking system enables to mix the air without pressing it through the heat exchanger.

# HEATING CAPACITIES

Tw1 / Tw2 = 90/70°C					Tw1 / Tw2 = 80/60°C					Tw1 / Tw2 = 70/50°C					Tw1 / Tw2 = 60/40°C					Tw1 / Tw2 = 50/40°C				
Tp1	PT	Qw	Δpw	Tp2	Tp1	PT	Qw	Δpw	Tp2	Tp1	PT	Qw	Δpw	Tp2	Tp1	PT	Qw	Δpw	Tp2	Tp1	PT	Qw	Δpw	Tp2
[°C]	[kW]	[l/h]	[kPa]	[°C]	[°C]	[kW]	[l/h]	[kPa]	[°C]	[°C]	[kW]	[l/h]	[kPa]	[°C]	[°C]	[kW]	[l/h]	[kPa]	[°C]	[°C]	[kW]	[l/h]	[kPa]	[°C]
AGRO ST = 3700 m³/h																								
0	43	1890	20	32,5	0	37,2	1630	16	28	0	31,3	1370	13	23,5	0	25,4	1110	11	19	0	23,8	2070	26	18
5	39,7	1750	17	35,5	5	34	1490	15	31	5	28,2	1230	11	26,5	5	22,4	980	9	22	5	20,8	1810	21	21
10	36,6	1610	15	38,5	10	30,9	1360	13	34	10	25,1	1100	10	29,5	10	19,4	840	7	25	10	17,8	1550	18	24
15	33,5	1470	15	41,5	15	27,8	1220	11	37	15	22,2	970	8	32,5	15	16,4	720	7	28	15	15	1300	13	27
20	30,4	1340	12	44,5	20	24,9	1090	10	40	20	19,2	840	6	35,5	20	13,5	590	5	31	20	12,1	1050	10	30
25	27,5	1210	10	47,5	25	21,9	960	8	43	25	16,3	710	6	38,5	25	10,7	460	5	34	25	9,3	810	6	33
30	24,5	1080	10	50,5	30	19,1	840	6	46	30	13,5	590	5	41,5	30	7,8	340	3	36,5	30	6,6	570	4	35,5
35	21,7	950	8	53,5	35	16,2	710	6	49	35	10,7	470	5	44	35	4,8	210	3	39	35	3,8	330	3	38

To obtain operating parameters concerning other water temperatures please contact Sales Office.

V – air flow

PT – heating capacity

Tp1 – inlet air temperature

Tp2 – outlet air temperature

Tw1 – inlet water temperature

Tw2 – outlet water temperature

Qw – water flow in the heat exchanger

Δpw – water pressure drop in the heat exchanger





---

# AIR CURTAINS AND AIR CURTAIN-FAN HEATER UNITS



# AIR CURTAINS AND AIR CURTAIN-FAN HEATER UNITS

## COMPARE ELiS SOLUTIONS

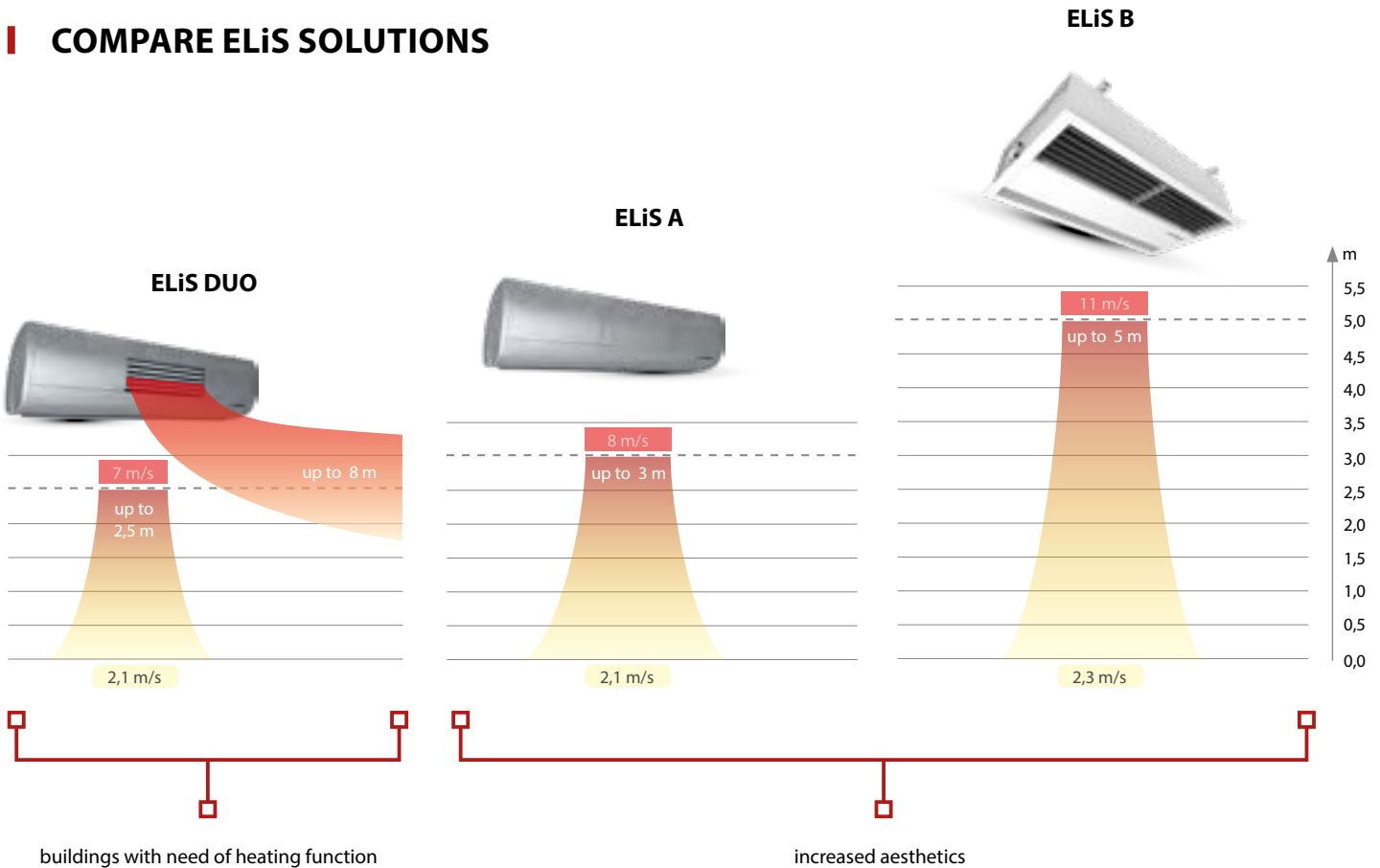

## TECHNICAL DATA

	ELiS DUO	ELiS A	ELiS B
<b>Version</b>	W/E	W/E/N	W/E/N
<b>Height of installation</b>	up to 2,5 m	up to 3 m	up to 5 m
<b>Air flow</b>	1200–3700 m <sup>3</sup> /h	850–3500 m <sup>3</sup> /h	2200–6600 m <sup>3</sup> /h
<b>Volume</b>	45–60 dB(A)	44–59 dB(A)	55–66 dB(A)
<b>BMS</b>	as standard	as standard	as standard

N – without heating elements    W – water heat exchanger    E – electric heaters

■ – Speed limit at the floor level

■ – Outlet air velocity

## APPLICATION



- reception
- banquet rooms
- shops



- exhibition centers
- banks
- airports



- hotels
- offices
- shopping centers

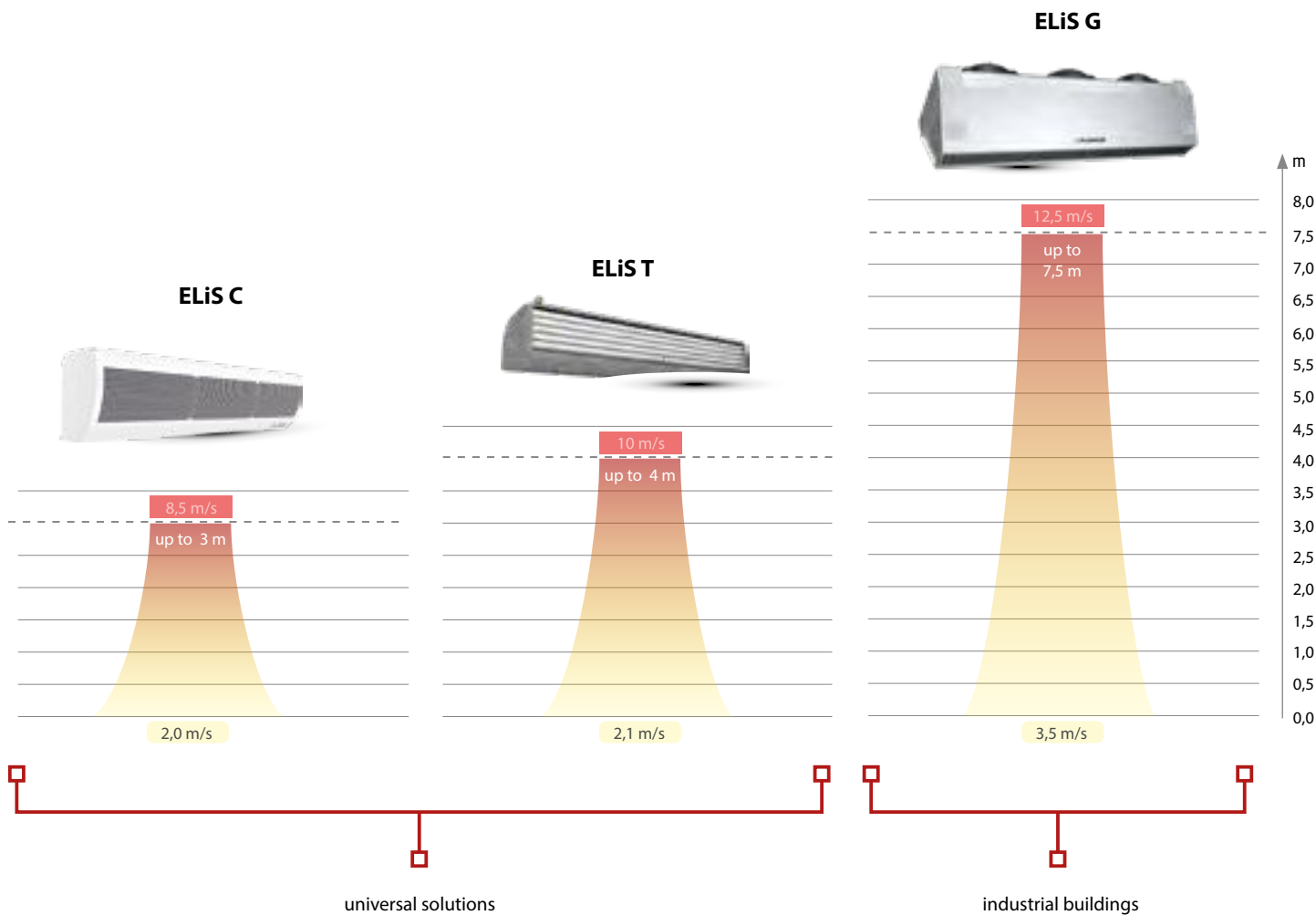

ELiS C	ELiS T	ELiS G
W/E	W/E/N	W/E/N
up to 3 m	up to 4 m	up to 7,5 m
900–3000 m <sup>3</sup> /h	1900–5300 m <sup>3</sup> /h	4100–8600 m <sup>3</sup> /h
49–56 dB(A)	55–65 dB(A)	44–68 dB(A)
via external DRV ELiS module	via external DRV ELiS module	via external DRV ELiS module

Average acoustic pressure level in the room of average sound absorption, volume of 1500 m<sup>3</sup>, at a distance of 5 m from the unit



- shops
- shopping centers
- petrol stations



- shopping centers
- restaurants
- train stations



- industrial halls
- logistics centers
- warehouses

# AIR CURTAINS

## ELiS C



SPECIAL PAINTING  
ON REQUEST

### Air curtains **ELiS C**

Range [m]	3
Heating capacity [kW]	14,9–32,5
Air flow [m <sup>3</sup> /h]	900–3000
Weight [kg]	14,5–35,1
Colour	white
Casing	steel



<sup>(1)</sup> According to ISO 27327-1

<sup>(2)</sup> For C-W at inlet/outlet water temperature 90/70°C, inlet air temperature 10°C

<sup>(3)</sup> RAL 9016

## APPLICATION

ELiS C air curtains are dedicated for public buildings like markets, sports halls, stores, restaurants, etc. ELiS C air curtains are designed for horizontal and vertical installation directly above door openings, where height does not exceed 3 m.

## AVAILABLE TYPES OF UNITS:

### 3 LENGTHS

1 m, 1,5 m or 2 m

### 2 VERSIONS

 water heat exchanger

 electric heaters

## TECHNICAL DATA

### Air curtains ELiS C

	ELiS C-W-100	ELiS C-E-100	ELiS C-W-150	ELiS C-E-150	ELiS C-W-200	ELiS C-E-200
Power supply [V/Hz]	230 / 50	3 x 400 / 50 lub 1 x 230 / 50	230 / 50	3 x 400 / 50	230 / 50	3 x 400 / 50
Max. power consumption [kW]	0,14	6,5	0,21	10,0	0,26	13,0
Max. current consumption [A]	0,65	9,4 (3x400) 28 (1x230)	0,95	14,5	1,2	18,7
IP	21/F	21/F	21/F	21/F	21/F	21/F
Connection (interior thread)	¾"	–	¾"	–	¾"	–
Curtain air flow stream [m <sup>3</sup> /h]	1400	1300	2100	1950	3000	2700
Acoustic pressure level [dB(A)] <sup>(1)</sup>	54	54	55	55	56	56
Acoustic power level [dB(A)] <sup>(2)</sup>	69	69	70	70	71	71
Max. water temperature [°C]	90	–	90	–	90	–
Max. operating pressure [MPa]	1,2	–	1,2	–	1,2	–
Curtain's air temperature rise (ΔT) [°C] <sup>(3)</sup>	31	15	32	15	32	15
Unit weight [kg]	19,0	14,5	27,5	19,9	35,1	25,1
Range [m] <sup>(4)</sup>	3	3	3	3	3	3

<sup>(1)</sup> Average acoustic pressure level in the room of average sound absorption, volume of 1500 m<sup>3</sup>, at a distance of 5 m from the unit

<sup>(2)</sup> Acoustic power according to ISO 27327-2

<sup>(3)</sup> For C-W at heating medium temperature 90/70°C, at air inlet to the device 10°C / for C-E at air inlet to the device 10°C

<sup>(4)</sup> According to ISO 27327-1

# INSTALLATION

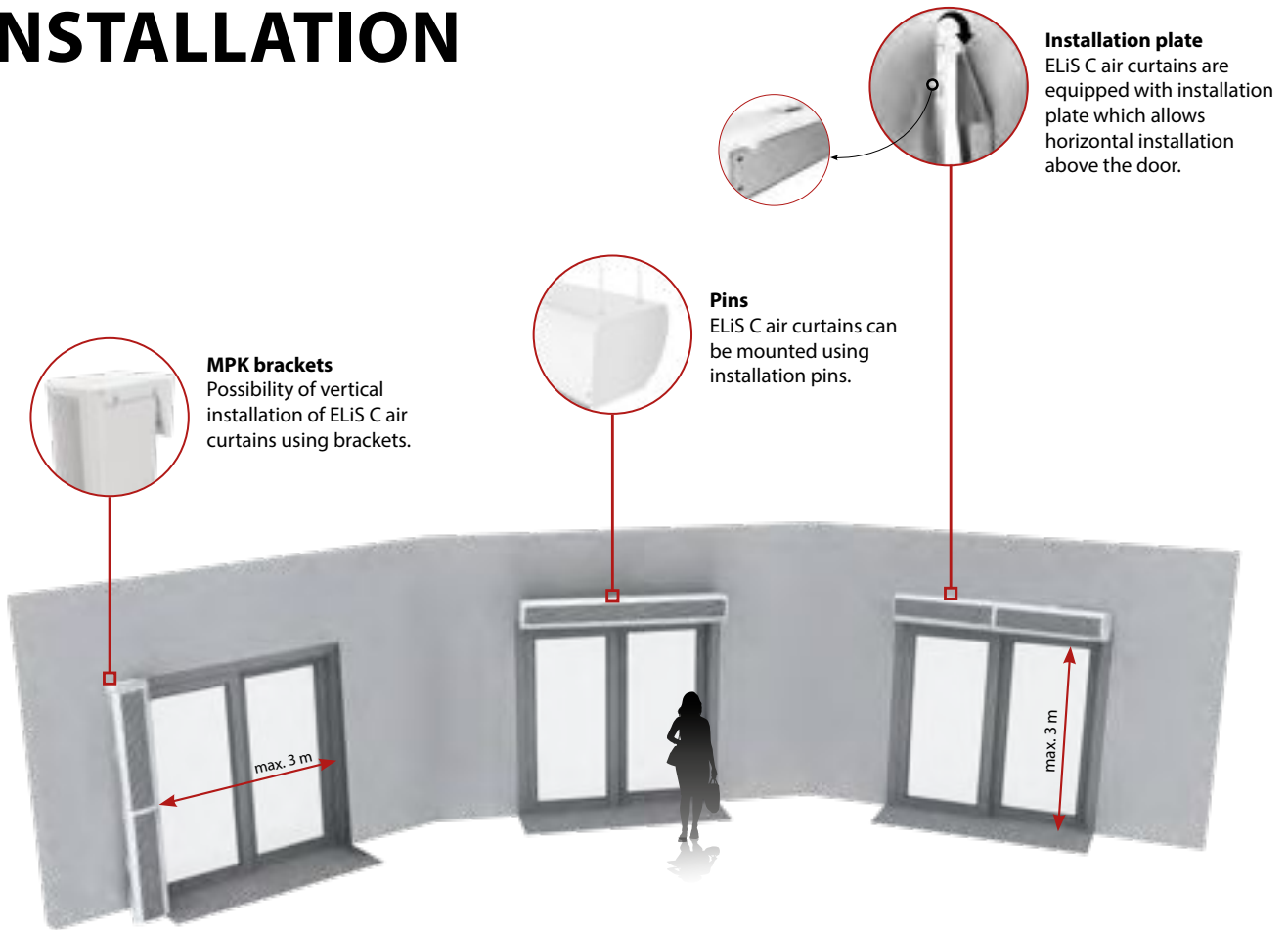

## DIMENSIONS

For CAD drawings, Revit files and documentation for all available versions of ELiS visit [www.flowair.com](http://www.flowair.com)

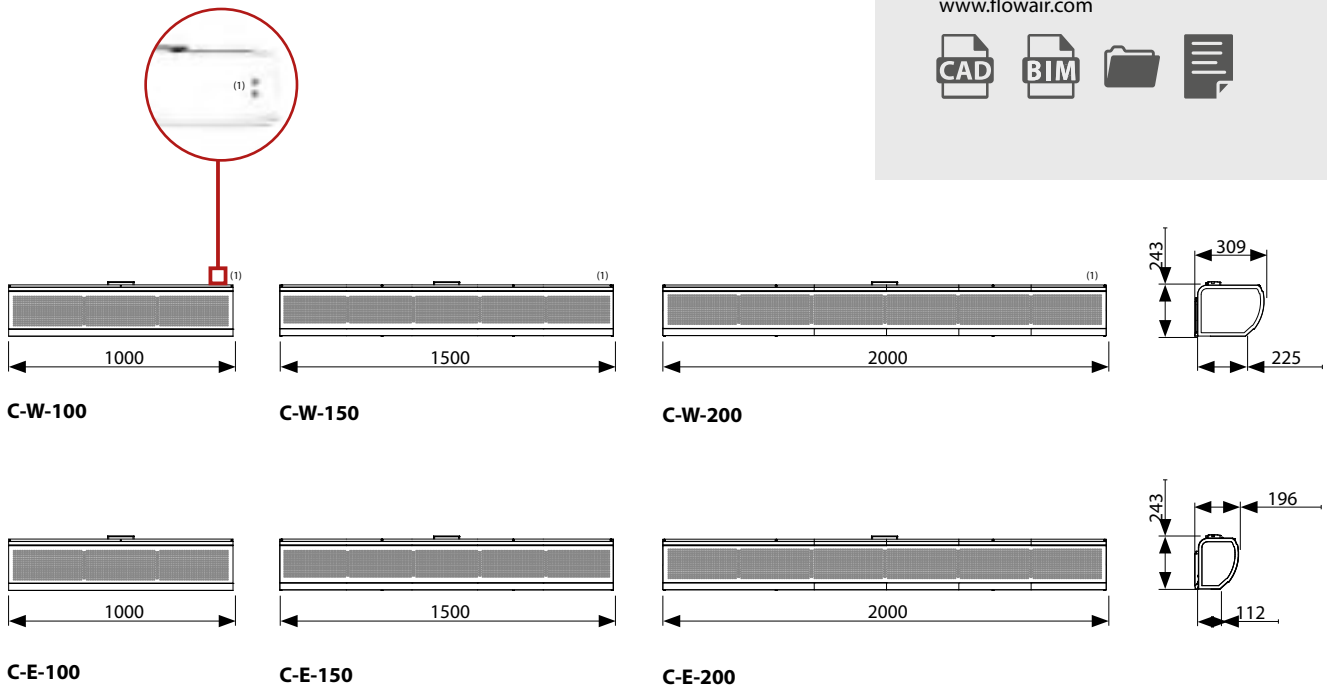

<sup>(1)</sup> Connection interior thread

# CONNECTION DIAGRAM

## TS CONTROLLER

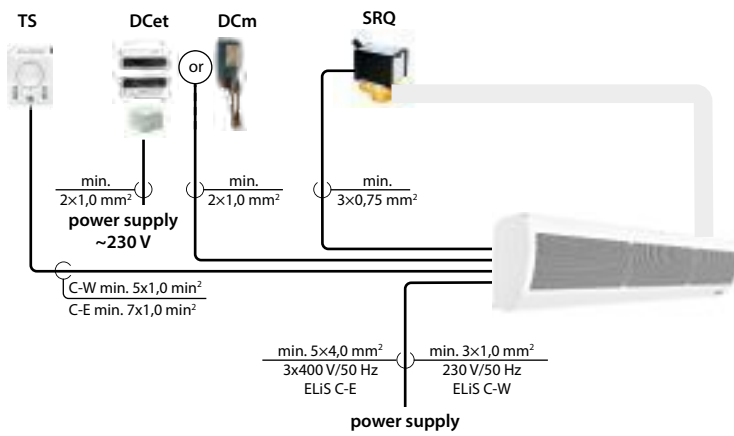

### ELEMENTS:

- TS – 3-step fan speed controller with thermostat
- DCet – magnetic door sensor with relay box
- DCm – mechanical door sensor
- SRQ – valve with actuator

ELiS C is compatible with T-box controller and DRV ELiS



ELiS C – EASY INSTALLATION

# HEATING CAPACITIES

Tw1/Tw2 = 90/70°C					Tw1/Tw2 = 80/60°C					Tw1/Tw2 = 70/50°C					Tw1/Tw2 = 60/40°C				
Tp1	PT	Qw	Δpw	Tp2	Tp1	PT	Qw	Δpw	Tp2	Tp1	PT	Qw	Δpw	Tp2	Tp1	PT	Qw	Δpw	Tp2
°C	kW	l/h	kPa	°C	°C	kW	l/h	kPa	°C	°C	kW	l/h	kPa	°C	°C	kW	l/h	kPa	°C
ELIS C-W-100																			
V = 1400 m <sup>3</sup> /h, III step																			
0,0	17,0	749	21,3	36,0	0,0	14,6	643	16,7	31,0	0,0	12,3	538	12,5	26,0	0,0	9,9	432	8,8	21,0
10,0	14,9	655	16,7	41,0	10,0	12,5	549	12,5	36,5	10,0	10,1	443	8,8	31,5	10,0	7,7	337	5,6	26,5
20,0	12,7	560	12,6	46,5	20,0	10,3	453	8,9	41,5	20,0	7,9	346	5,7	36,5	20,0	5,5	238	3,1	31,5
ELIS C-W-150																			
V = 2100 m <sup>3</sup> /h, III step																			
0,0	26,1	1150	22,7	36,5	0,0	22,5	988	17,7	31,5	0,0	18,9	826	13,2	26,5	0,0	15,3	666	9,3	21,5
10,0	22,8	1006	17,8	42,0	10,0	19,2	843	13,3	37,0	10,0	15,6	681	9,4	32,0	10,0	11,9	519	6,0	26,5
20,0	19,5	860	13,4	47,0	20,0	15,8	696	9,4	42,0	20,0	12,2	533	6,0	37,0	20,0	8,5	368	3,3	32,0
ELIS C-W-200																			
V = 3000 m <sup>3</sup> /h, III step																			
0,0	37,1	1638	53,5	36,5	0,0	32,1	1411	41,9	31,5	0,0	27,1	1185	31,5	26,5	0,0	22,0	961	22,4	22,0
10,0	32,5	1436	42,0	42,0	10,0	27,5	1207	31,6	37,0	10,0	22,4	981	22,4	32,0	10,0	17,3	755	14,5	27,0
20,0	27,9	1229	31,7	47,0	20,0	22,8	1000	22,4	42,0	20,0	17,6	772	14,6	37,0	20,0	12,5	543	8,1	32,0

V – air flow  
 PT – heating capacity  
 Tp1 – inlet air temperature

Tp2 – outlet air temperature  
 Tw1 – inlet water temperature  
 Tw2 – outlet water temperature

Qw – water flow in the heat exchanger  
 Δpw – water pressure drop in the heat exchanger

# AIR CURTAINS ELiS T

## Air curtains ELiS T

Range [m]	4
Heating capacity [kW]	11,1–49,3
Air flow [m <sup>3</sup> /h]	1900–5300
Weight [kg]	20,7–37,5
Colour	grey
Casing	steel, EPP



<sup>(1)</sup> According to ISO 27327-1

<sup>(2)</sup> For T-W at inlet/outlet water temperature 90/70°C, inlet air temperature 10°C

<sup>(3)</sup> RAL 9007

## APPLICATION

Modern shape and small size makes it suitable to install the units both in representative and industrial buildings ELiS T air curtains are designed for both horizontal mounting – directly above the door openings – and vertical mounting on the side of the door opening.

## AVAILABLE TYPES OF UNITS:

- **3 LENGTHS**  
1 m, 1,5 m or 2 m

- **3 VERSIONS**

- ⊕ water heat exchanger (1- or 2-rows)
- Ⓝ without heating elements („ambient“)
- ⚡ electric heaters

## TECHNICAL DATA

### Air curtains ELiS T

	ELiS T-W- 100	ELiS T-W- 100 2R	ELiS T-N- 100	ELiS T-E- 100	ELiS T-W- 150	ELiS T-W- 150 2R	ELiS T-N- 150	ELiS T-E- 150	ELiS T-W- 200	ELiS T-W- 200 2R	ELiS T-N- 200	ELiS T-E- 200
Power supply [V/Hz]	230 / 50	230 / 50	230 / 50	3 x 400 / 50	230 / 50	230 / 50	230 / 50	3 x 400 / 50	230 / 50	230 / 50	230 / 50	3 x 400 / 50
Max. power consumption [kW]	0,38	0,38	0,39	7,5	0,4	0,4	0,42	11,5	0,44	0,44	0,46	15,5
Max. current consumption [A]	1,7	1,7	1,8	11	1,8	1,8	1,9	16,6	2,0	2,0	2,1	22,4
IP	21/F	21/F	21/F	21/F	21/F	21/F	21/F	21/F	21/F	21/F	21/F	21/F
Connection	½"	½"	-	-	½"	½"	-	-	½"	½"	-	-
Curtain air flow stream [m <sup>3</sup> /h]	2300	2100	2900	2300	3900	3700	4000	3900	5100	4900	5300	5100
Acoustic pressure level [dB(A)] <sup>(1)</sup>	60	59	63	60	61	60	64	61	62	61	65	62
Acoustic power level [dB(A)] <sup>(2)</sup>	75	74	78	75	76	75	79	76	77	76	80	77
Max. water temperature [°C]	95	95	-	-	95	95	-	-	95	95	-	-
Max. operating pressure [MPa]	1,6	1,6	-	-	1,6	1,6	-	-	1,6	1,6	-	-
Curtain's air temperature rise (ΔT) [°C] <sup>(3)</sup>	14	27	-	11	15	29	-	12	16	30	-	13
Unit weight [kg]	22,1	23,5	20,7	24,0	29,5	32,0	27,0	31,5	34,3	37,5	31,5	37,0
Range [m] <sup>(4)</sup>	4	4	4	4	4	4	4	4	4	4	4	4

<sup>(1)</sup> Average acoustic pressure level in the room of average sound absorption, volume of 1500 m<sup>3</sup>, at a distance of 5 m from the unit

<sup>(2)</sup> Acoustic power according to ISO 27327-2

<sup>(3)</sup> For T-W at heating medium temperature 90/70°C, at air inlet to the device 10°C / for T-E at air inlet to the device 10°C

<sup>(4)</sup> According to ISO 27327-1



# INSTALLATION

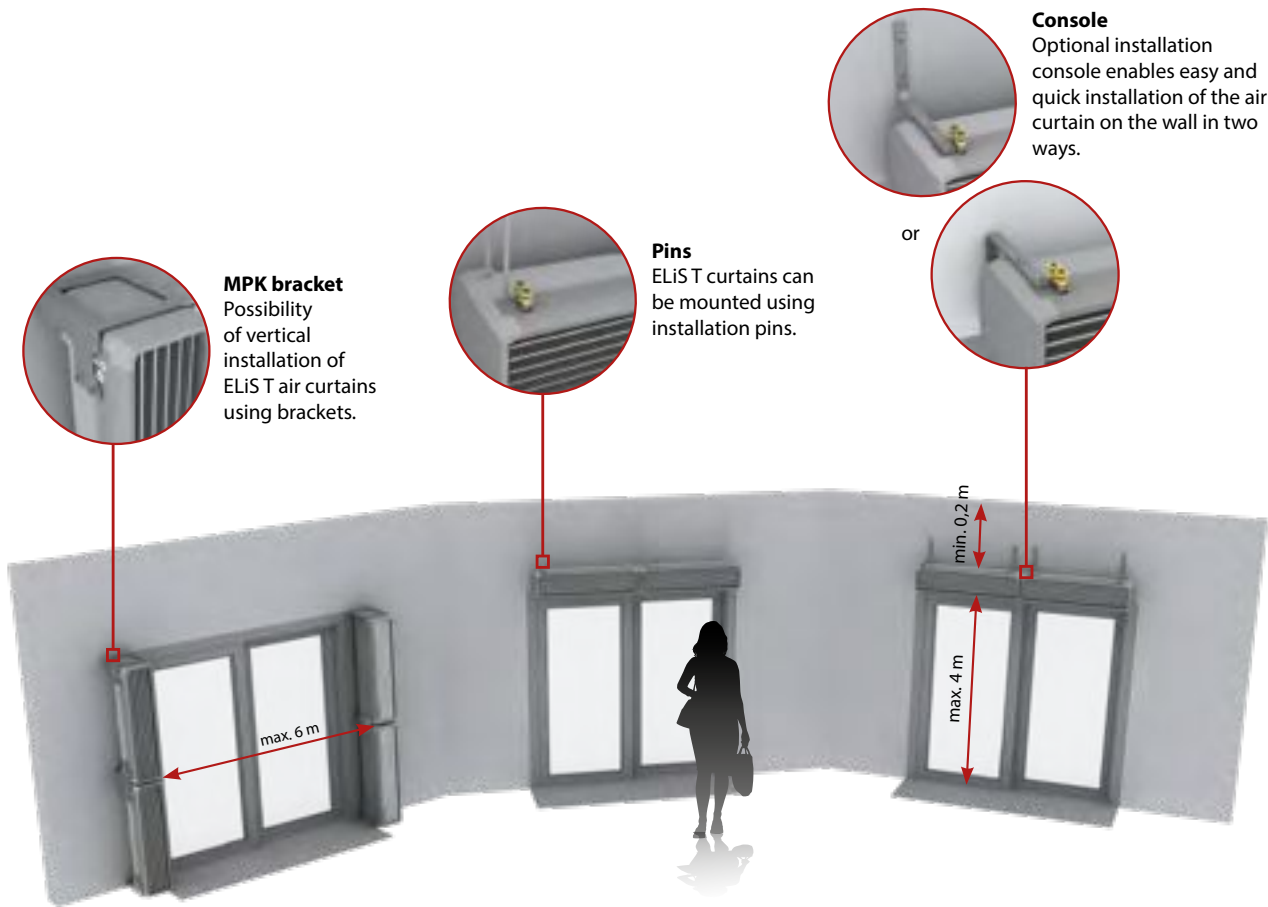

## DIMENSIONS

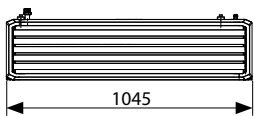

T-N/W/E-100

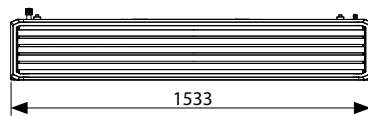

T-N/W/E-150

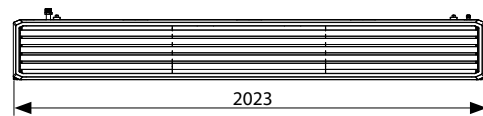

T-N/W/E-200

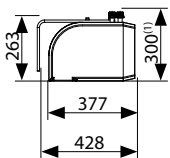

For CAD drawings, Revit files and documentation for all available versions of ELiS visit [www.flowair.com](http://www.flowair.com)



<sup>(1)</sup> The dimension refers to a curtain with an ELiS T-W exchanger.

# CONNECTION DIAGRAMS

## TS CONTROLLER

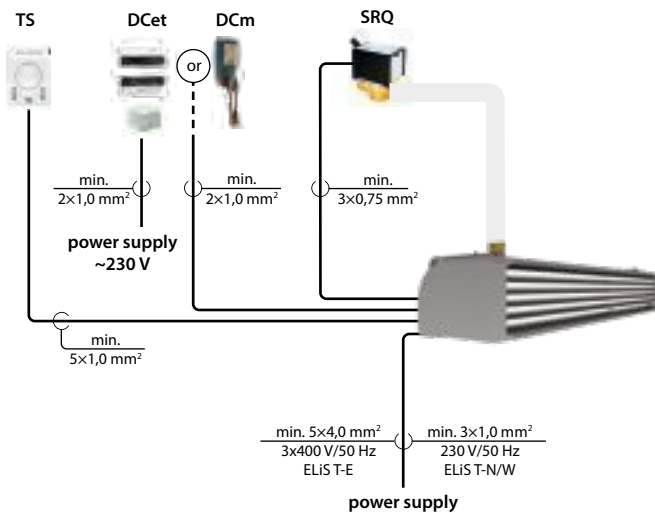

## T-box CONTROLLER

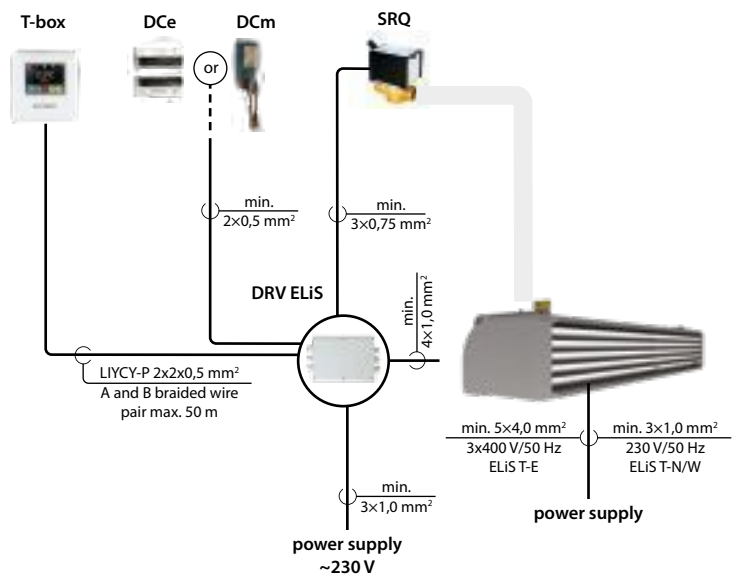

### ELEMENTS:

- **TS** – 3-step fan speed controller with thermostat
- **DCeT** – magnetic door sensor with relay box
- **DCm** – mechanical door sensor
- **SRQ** – valve with actuator

### ELEMENTS:

- **T-box** – intelligent controller with touch screen
- **DRV ELiS** – external control module
- **DCe** – magnetic door sensor
- **DCm** – mechanical door sensor
- **SRQ** – valve with actuator

## ELiS T – UNIVERSAL INSTALLATION OPTION



# HEATING CAPACITIES

Tw1/Tw2 = 90/70°C					Tw1/Tw2 = 80/60°C					Tw1/Tw2 = 70/50°C					Tw1/Tw2 = 60/40°C				
Tp1	PT	Qw	Δpw	Tp2	Tp1	PT	Qw	Δpw	Tp2	Tp1	PT	Qw	Δpw	Tp2	Tp1	PT	Qw	Δpw	Tp2
°C	kW	l/h	kPa	°C	°C	kW	l/h	kPa	°C	°C	kW	l/h	kPa	°C	°C	kW	l/h	kPa	°C
ELIS T-W-100																			
V = 2300 m³/h, III step																			
0,0	12,9	571	2	17	0,0	10,8	476	1,5	14	0,0	8,7	379	1	11	0,0	6,3	276	0,6	8
10,0	11,1	492	1,5	24,5	10,0	9	395	1,1	21,5	10,0	6,8	296	0,7	18,5	10,0	4,2	183	0,3	15
20,0	9,3	411	1,1	32	20,0	7,1	314	0,7	29	20,0	4,8	210	0,4	26	20,0	1,7	73	0,1	22
ELIS T-W-150																			
V = 3900 m³/h, III step																			
0,0	23,2	1026	7,2	17,5	0,0	19,8	870	5,5	15	0,0	16,3	714	4	12	0,0	12,8	556	2,6	9
10,0	20,2	892	5,6	25	10,0	16,7	735	4	22,5	10,0	13,2	578	2,7	20	10,0	9,6	417	1,6	16,5
20,0	17,2	757	4,1	32,5	20,0	13,6	599	2,8	30	20,0	10	439	1,6	27,5	20,0	6,2	272	0,07	24
ELIS T-W-200																			
V = 5100 m³/h, III step																			
0,0	31,4	1387	14,5	18	0,0	26,9	1183	11,1	15	0,0	22,4	980	8,1	12,5	0,0	17,8	776	5,5	10
10,0	27,4	1211	11,3	26	10,0	22,9	1005	8,2	23	10,0	18,3	801	5,6	20,5	10,0	13,6	595	3,4	18
20,0	23,4	1033	8,4	33	20,0	18,8	826	5,8	30,5	20,0	14,4	619	3,5	27,5	20,0	9,4	408	1,7	25
ELIS T-W-100 2R																			
V = 2100 m³/h, III step																			
0,0	22,6	998	1,57	32	0,0	18,9	832	1,16	27	0,0	15,1	662	0,79	21	0,0	11	479	0,46	16
10,0	19,5	858	1,19	37	10,0	15,7	691	0,83	32	10,0	11,8	517	0,51	27	10,0	6,96	304	0,2	19
20,0	16,3	718	0,86	43	20,0	12,5	547	0,54	37	20,0	78,3	362	0,27	31	20,0	3,17	138	0,5	24
ELIS T-W-150 2R																			
V = 3700 m³/h, III step																			
0,0	41,5	1833	5,9	33	0,0	35,4	1555	4,48	28	0,0	29,2	1276	3,22	23	0,0	22,8	994	2,1	18
10,0	36,1	1592	4,6	39	10,0	29,9	1313	3,29	34	10,0	23,6	1032	2,2	29	10,0	17,1	746	1,27	24
20,0	30,6	1351	3,4	44	20,0	24,3	1069	2,27	39	20,0	17,9	785	1,34	34	20,0	11,1	483	0,58	29
ELIS T-W-200 2R																			
V = 4900 m³/h, III step																			
0,0	56,5	2494	11,95	34	0,0	48,4	2127	9,17	29	0,0	40,3	1762	6,7	24	0,0	32	1396	4,54	19
10,0	49,3	2174	9,28	40	10,0	41,1	1806	6,8	35	10,0	32,9	1439	4,64	30	10,0	24,5	1069	2,81	25
20,0	42	1854	6,93	45	20,0	33,7	1483	4,75	40	20,0	25,4	1111	2,91	35	20,0	16,8	732	1,43	30

V – air flow  
 PT – heating capacity  
 Tp1 – inlet air temperature

Tp2 – outlet air temperature  
 Tw1 – inlet water temperature  
 Tw2 – outlet water temperature

Qw – water flow in the heat exchanger  
 Δpw – water pressure drop in the heat exchanger



SPECIAL PAINTING  
ON REQUEST

# AIR CURTAINS ELiS B



## Air curtains ELiS B

Range [m]	5
Heating capacity [kW]	10,9–49,9
Air flow [m <sup>3</sup> /h]	2200–6600
Weight [kg]	31,7–53,2
Colour	white
Casing	steel, plastic, EPP, aluminium

<sup>(1)</sup> According to ISO 27327-1

<sup>(2)</sup> For B-W at inlet/outlet water temperature 90/70°C, inlet air temperature 10°C

<sup>(3)</sup> RAL 9019

## APPLICATION

ELiS B air curtains are dedicated for shops, restaurants, exhibition rooms. Units are designed for installation in the ceilings. Advantage is the possibility to install in the existing ceilings without cutting additional holes.

## AVAILABLE TYPES OF UNITS:

- **3 LENGTHS**  
1 m, 1,5 m or 2 m
- **3 VERSIONS**
  - ⊕ water heat exchanger (1- or 2-rows)
  - Ⓝ without heating elements („ambient“)
  - ⚡ electric heaters

## TECHNICAL DATA

### Air curtains ELiS B

	ELiS B-W-100		ELiS B-W-100 2R		ELiS B-N-100		ELiS B-E-100		ELiS B-W-150		ELiS B-W-150 2R		ELiS B-N-150		ELiS B-E-150		ELiS B-W-200		ELiS B-W-200 2R		ELiS B-N-200		ELiS B-E-200			
	100	100 2R	100	100	150	150 2R	150	150	200	200 2R	200	200	3 x 400 / 50	3 x 400 / 50	3 x 400 / 50	3 x 400 / 50	3 x 400 / 50	3 x 400 / 50	3 x 400 / 50	3 x 400 / 50	3 x 400 / 50	3 x 400 / 50	3 x 400 / 50	3 x 400 / 50	3 x 400 / 50	
Power supply [V/Hz]	230 / 50	230 / 50	230 / 50	3 x 400 / 50	230 / 50	230 / 50	230 / 50	3 x 400 / 50	230 / 50	230 / 50	230 / 50	3 x 400 / 50	230 / 50	230 / 50	230 / 50	230 / 50	230 / 50	230 / 50	230 / 50	230 / 50	230 / 50	230 / 50	3 x 400 / 50	3 x 400 / 50	3 x 400 / 50	
Max. power consumption [kW]	0,34	0,34	0,42	7,5	0,36	0,36	0,42	11,5	0,38	0,38	0,49	15,5	0,34	0,34	0,42	11,5	0,38	0,38	0,49	15,5	0,34	0,34	0,42	11,5	0,34	
Max. current consumption [A]	1,5	1,5	1,9	11	1,6	1,6	2	16,6	1,7	1,7	2,2	22,4	1,5	1,5	1,9	11	1,6	1,6	2	16,6	1,7	1,7	2,2	22,4	1,5	
IP	21/F	21/F	21/F	21/F	21/F	21/F	21/F	21/F	21/F	21/F	21/F	21/F	21/F	21/F	21/F	21/F	21/F	21/F	21/F	21/F	21/F	21/F	21/F	21/F	21/F	
Connection	½"	½"	-	-	½"	½"	-	-	½"	½"	-	-	½"	½"	-	-	½"	½"	-	-	½"	½"	-	-	½"	½"
Curtain air flow stream [m <sup>3</sup> /h]	2600	2400	3500	2600	4000	3800	4800	4000	5200	4900	6600	5200	2600	2400	3500	2600	4000	3800	4800	4000	5200	4900	6600	5200	2600	
Acoustic pressure level [dB(A)] <sup>(1)</sup>	58	57	65	58	62	60	65	62	63	61	66	63	58	57	65	58	62	60	65	62	63	61	66	63	58	
Acoustic power level [dB(A)] <sup>(2)</sup>	73	72	80	73	77	75	80	77	78	76	81	78	73	72	80	73	77	75	80	77	78	76	81	78	73	
Max. water temperature [°C]	95	95	-	-	95	95	-	-	95	95	-	-	95	95	-	-	95	95	-	-	95	95	-	-	95	
Max. operating pressure [MPa]	1,6	1,6	-	-	1,6	1,6	-	-	1,6	1,6	-	-	1,6	1,6	-	-	1,6	1,6	-	-	1,6	1,6	-	-	1,6	
Curtain's air temperature rise (ΔT) [°C] <sup>(3)</sup>	15	28	-	11	15	31	-	12	16	33	-	13	15	28	-	11	15	31	-	12	16	33	-	13	15	
Unit weight [kg]	32,3	33,7	31,7	34,5	41,2	43,7	38,9	42,4	50	53,2	47,2	53,2	32,3	33,7	31,7	34,5	41,2	43,7	38,9	42,4	50	53,2	47,2	53,2	32,3	
Range [m] <sup>(4)</sup>	5	5	5	5	5	5	5	5	5	5	5	5	5	5	5	5	5	5	5	5	5	5	5	5	5	

<sup>(1)</sup> Average acoustic pressure level in the room of average sound absorption, volume of 1500 m<sup>3</sup>, at a distance of 5 m from the unit

<sup>(2)</sup> Acoustic power according to ISO 27327-2

<sup>(3)</sup> For B-W at heating medium temperature 90/70°C, at air inlet to the device 10°C / for B-E at air inlet to the device 10°C

<sup>(4)</sup> According to ISO 27327-1

# INSTALLATION



**Brackets**  
Brackets for installation using pins are included.



Installation of the unit doesn't require additional holes in the ceiling.

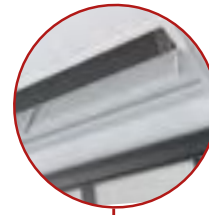

Access from the front makes installation, connection and cleaning the air curtain much easier.



## DIMENSIONS

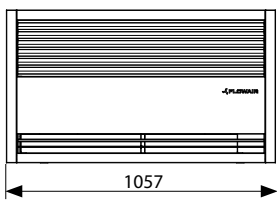

B-N/W/E-100

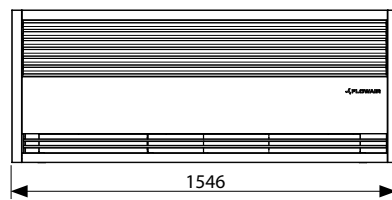

B-N/W/E-150

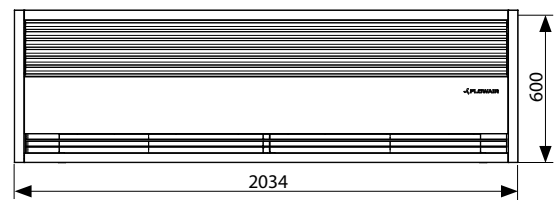

B-N/W/E-200

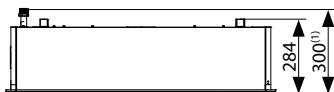

For CAD drawings, Revit files and documentation for all available versions of ELiS visit [www.flowair.com](http://www.flowair.com)



<sup>(1)</sup> The dimension refers to a curtain with an ELiS B-W exchanger.

# CONNECTION DIAGRAMS

## TS CONTROLLER

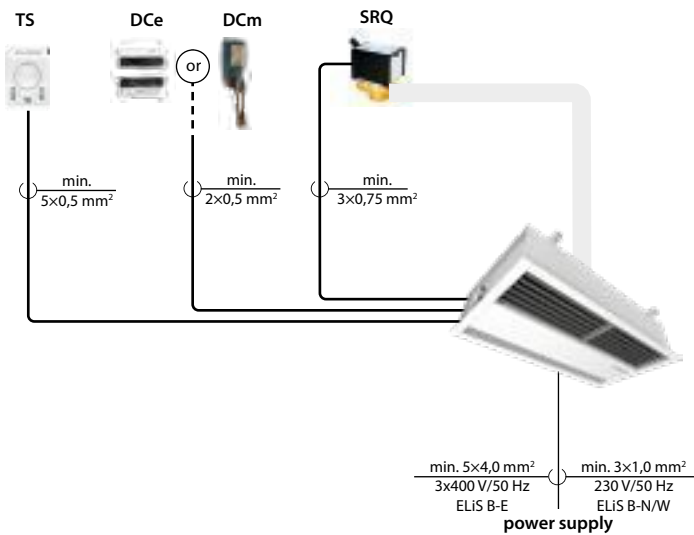

### ELEMENTS:

- **TS** – 3-step fan speed controller with thermostat
- **DCe** – magnetic door sensor
- **DCm** – mechanical door sensor
- **SRQ** – valve with actuator

## T-box CONTROLLER

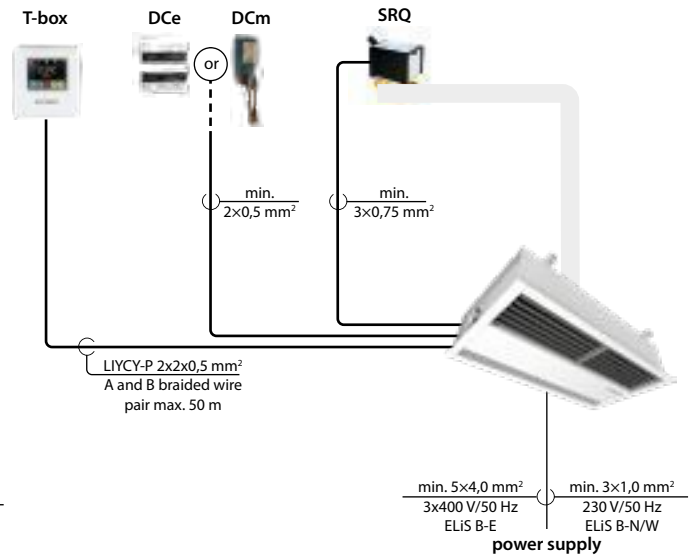

### ELEMENTS:

- **T-box** – intelligent controller with touch screen
- **DCe** – magnetic door sensor
- **DCm** – mechanical door sensor
- **SRQ** – valve with actuator

## ELiS B – RECESSED AIR CURTAINS



# HEATING CAPACITIES

Tw1/Tw2 = 90/70°C					Tw1/Tw2 = 80/60°C					Tw1/Tw2 = 70/50°C					Tw1/Tw2 = 60/40°C				
Tp1	PT	Qw	Δpw	Tp2	Tp1	PT	Qw	Δpw	Tp2	Tp1	PT	Qw	Δpw	Tp2	Tp1	PT	Qw	Δpw	Tp2
°C	kW	l/h	kPa	°C	°C	kW	l/h	kPa	°C	°C	kW	l/h	kPa	°C	°C	kW	l/h	kPa	°C
ELIS B-W-100																			
V = 2600 m³/h, III step																			
0,0	13,8	609	2,3	15,5	0,0	11,5	507	1,7	13,0	0,0	9,2	404	1,2	10,5	0,0	6,8	295	0,7	7,5
10,0	11,9	524	1,7	24,5	10,0	9	395	1,1	21,5	10,0	7,2	316	0,7	18,0	10,0	4,6	198	0,3	15,0
20,0	9,9	438	1,2	31,0	20,0	7,6	334	0,8	28,5	20,0	5,1	225	0,4	25,0	20,0	1,7	74	0,1	22,0
ELIS B-W-150																			
V = 4000 m³/h, III step																			
0,0	23,5	1039	7,4	17,5	0,0	20,0	881	5,6	15,0	0,0	16,5	723	4,0	12,5	0,0	13,0	563	2,7	9,5
10,0	20,5	904	5,7	25,0	10,0	17,0	745	4,1	22,5	10,0	13,4	585	2,8	20,0	10,0	9,7	423	1,6	17,0
20,0	17,4	767	4,2	32,5	20,0	13,8	607	2,8	30,0	20,0	10,2	445	1,7	27,5	20,0	6,3	276	0,7	24,5
ELIS B-W-200																			
V = 5200 m³/h, III step																			
0,0	31,8	1402	14,7	18,0	0,0	7,7	1195	11,3	15,5	0,0	22,5	990	8,3	13,0	0,0	18,0	784	5,6	10,5
10,0	27,7	1223	11,5	25,7	10,0	23,1	1016	8,4	22,5	10,0	18,5	809	5,7	20,5	10,0	13,8	601	3,5	18,0
20,0	23,6	1043	8,8	33,0	20,0	19,0	834	5,9	30,5	20,0	14,3	625	3,6	28,0	20,0	9,5	412	1,8	25,0
ELIS B-W-100 2R																			
V = 2400 m³/h, III step																			
0,0	24,5	1080	11,82	30	0,0	20,5	900	1,34	25	0,0	11,8	716	0,91	20	0,0	12	521	0,53	15
10,0	21	928	1,38	36	10,0	17	747	0,95	31	10,0	12,8	560	0,58	26	10,0	7,8	341	0,25	20
20,0	17,6	776	0,99	41	20,0	13,5	592	0,63	36	20,0	9	395	0,31	31	20,0	3,3	142	0,05	24
ELIS B-W-150 2R																			
V = 3800 m³/h, III step																			
0,0	42,2	1863	6,1	33	0,0	36	1580	4,6	28	0,0	29,6	1296	3,3	23	0,0	23,2	1010	2,2	18
10,0	39,4	1618	4,7	38,5	10,0	30,4	1334	3,4	33,5	10,0	24	1049	2,3	28,5	10,0	17,4	758	1,3	23,5
20,0	31,1	1373	3,5	44	20,0	24,7	1086	2,3	39	20,0	18,2	797	1,4	34	20,0	11,3	492	0,6	28,5
ELIS B-W-200 2R																			
V = 4900 m³/h, III step																			
0,0	57,2	2524	12,2	34	0,0	49	2153	9,37	29	0,0	40,8	1783	6,85	24	0,0	32,4	1413	4,64	19
10,0	49,9	2200	9,49	39	10,0	41,6	1828	6,95	34	10,0	33,3	1456	4,74	30	10,0	24,8	1082	2,87	25
20,0	42,5	1876	7,09	45	20,0	34,2	1501	4,85	40	20,0	25,7	1125	2,97	35	20,0	17	741	1,46	30

V – air flow  
 PT – heating capacity  
 Tp1 – inlet air temperature

Tp2 – outlet air temperature  
 Tw1 – inlet water temperature  
 Tw2 – outlet water temperature

Qw – water flow in the heat exchanger  
 Δpw – water pressure drop in the heat exchanger

# AIR CURTAINS ELiS A



SPECIAL PAINTING  
ON REQUEST

## Air curtains **ELiS A**

Range [m]	3
Heating capacity [kW]	17,6–28,0
Air flow [m <sup>3</sup> /h]	850–3500
Weight [kg]	18,4–39,0
Colour	grey
Casing	steel, plastic



<sup>(1)</sup> According to ISO 27327-1

<sup>(2)</sup> For A-W at inlet/outlet water temperature 90/70°C, inlet air temperature 10°C

<sup>(3)</sup> RAL 9006

## APPLICATION

Representative rooms such as shops, restaurants, exhibition rooms, etc. ELiS A devices are designed for horizontal installation directly above door openings. They produce an air barrier that reduces heat/cool losses.

## AVAILABLE TYPES OF UNITS:

### 3 LENGTHS

1 m, 1,5 m or 2 m

### 3 VERSIONS

water heat exchanger

without heating elements („ambient“)

electric heaters

## TECHNICAL DATA

### Air curtains

#### ELiS A

	ELiS A-W-100	ELiS A-N-100	ELiS A-E-100	ELiS A-W-150	ELiS A-N-150	ELiS A-E-150	ELiS A-W-200	ELiS A-N-200	ELiS A-E-200
Power supply [V/Hz]	230 / 50	230 / 50	3 x 400 / 50	230 / 50	230 / 50	3 x 400 / 50	230 / 50	230 / 50	3 x 400 / 50
Max. power consumption [kW]	0,17	0,17	7,0	0,25	0,25	10,7	0,34	0,34	15,0
Max. current consumption [A]	0,72	0,72	10,0	1,1	1,1	15,5	1,45	1,45	21,5
IP	21/F	21/F	21/F	21/F	21/F	21/F	21/F	21/F	21/F
Connection	½"	-	-	½"	-	-	½"	-	-
Curtain air flow stream [m <sup>3</sup> /h]	1500	1500	1500	2500	2500	2500	3500	3500	3500
Acoustic pressure level [dB(A)] <sup>(1)</sup>	57	57	57	58	58	58	59	59	59
Acoustic power level [dB(A)] <sup>(2)</sup>	72	72	72	73	73	73	74	74	74
Max. water temperature [°C]	95	-	-	95	-	-	95	-	-
Max. operating pressure [MPa]	1,6	-	-	1,6	-	-	1,6	-	-
Curtain's air temperature rise (ΔT) [°C] <sup>(3)</sup>	34	-	25	25	-	21	24	-	18
Unit weight [kg]	20,9	18,4	21,4	28,3	25,3	28,5	37,1	33,6	39,0
Range [m] <sup>(4)</sup>	3	3	3	3	3	3	3	3	3

<sup>(1)</sup> Average acoustic pressure level in the room of average sound absorption, volume of 1500 m<sup>3</sup>, at a distance of 5 m from the unit

<sup>(2)</sup> Acoustic power according to ISO 27327-2

<sup>(3)</sup> For A-W at heating medium temperature 90/70°C, at air inlet to the device 10°C / for A-E at air inlet to the device 10°C

<sup>(4)</sup> According to ISO 27327-1



# INSTALLATION



## DIMENSIONS

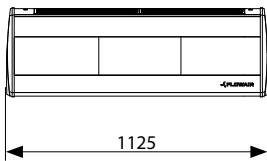

A-N/W/E-100

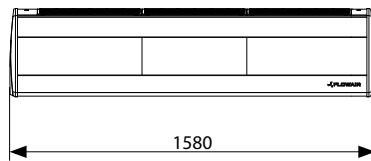

A-N/W/E-150

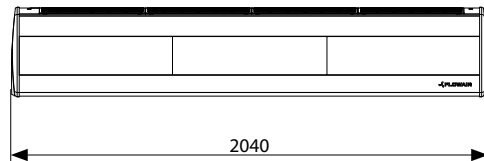

A-N/W/E-200

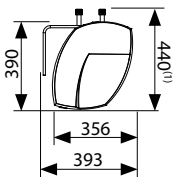

<sup>(1)</sup> The dimension refers to a curtain with an ELiS A-W exchanger.

For CAD drawings, Revit files and documentation for all available versions of ELiS visit [www.flowair.com](http://www.flowair.com)



# CONNECTION DIAGRAMS

## TS CONTROLLER

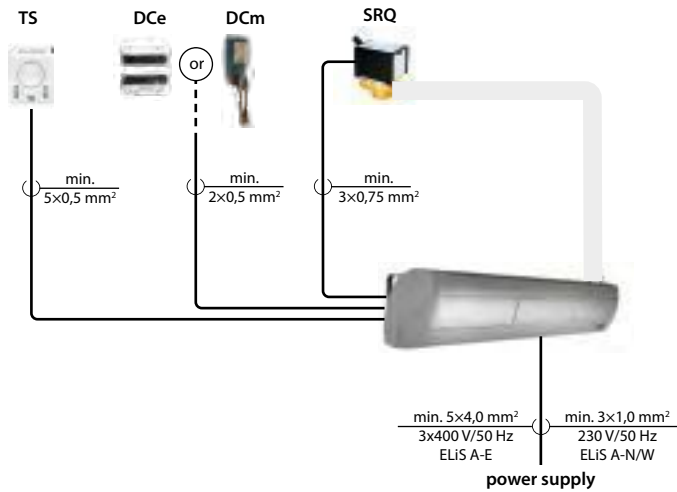

## T-box CONTROLLER

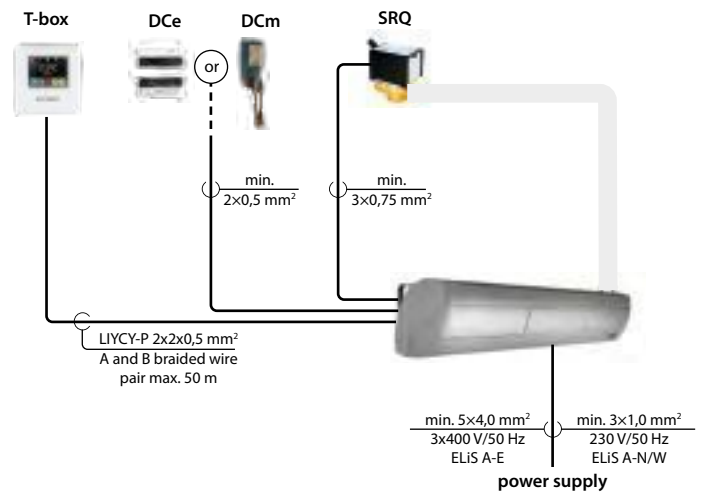

### ELEMENTS:

- **TS** – 3-step fan speed controller with thermostat
- **DCe** – magnetic door sensor
- **DCm** – mechanical door sensor
- **SRQ** – valve with actuator

### ELEMENTS:

- **T-box** – intelligent controller with touch screen
- **DCe** – magnetic door sensor
- **DCm** – mechanical door sensor
- **SRQ** – valve with actuator

**ELiS A – REPRESENTATIVE AND AESTHETIC SPACES**



# HEATING CAPACITIES

Tw1/Tw2 = 90/70°C					Tw1/Tw2 = 80/60°C					Tw1/Tw2 = 70/50°C					Tw1/Tw2 = 60/40°C				
Tp1	PT	Qw	Δpw	Tp2	Tp1	PT	Qw	Δpw	Tp2	Tp1	PT	Qw	Δpw	Tp2	Tp1	PT	Qw	Δpw	Tp2
°C	kW	l/h	kPa	°C	°C	kW	l/h	kPa	°C	°C	kW	l/h	kPa	°C	°C	kW	l/h	kPa	°C
ELIS A-W-100																			
V = 1500 m <sup>3</sup> /h, III step																			
0,0	20,1	887	8,1	40	0,0	17,3	759	6,2	34	0,0	14,4	631	4,6	28	0,0	11,5	502	3,2	23
10,0	17,6	775	6,3	44	10,0	14,7	646	4,7	39	10,0	11,8	517	3,2	33	10,0	8,9	87	2,0	27
20,0	15,0	663	4,7	49	20,0	12,1	533	3,3	43	20,0	9,2	402	2,0	38	20,0	6,1	267	1,0	32
ELIS A-W-150																			
V = 2500 m <sup>3</sup> /h, III step																			
0,0	22,9	1011	8,3	27	0,0	19,6	861	6,3	23	0,0	16,2	709	4,6	19	0,0	12,9	377	1,5	15
10,0	20	881	6,5	34	10,0	16,6	728	4,7	30	10,0	13,2	576	3,1	26	10,0	9,8	284	0,9	21
20,0	17	748	4,8	40	20,0	13,5	593	3,2	36	20,0	10	439	1,9	32	20,0	6,2	181	0,4	27
ELIS A-W-200																			
V = 3500 m <sup>3</sup> /h, III step																			
0,0	32,2	1419	18	27	0,0	27,6	1212	13,6	23	0,0	23	1007	10	20	0,0	18,4	801	6,7	16
10,0	28	1240	14	34	10,0	23,5	1031	10,1	30	10,0	18,9	824	6,9	26	10,0	14,1	616	4,2	22
20,0	24	1054	10,3	40	20,0	19,2	845	7	36	20,0	14,6	637	4,3	32	20,0	9,8	425	2,2	28

V – air flow  
 PT – heating capacity  
 Tp1 – inlet air temperature

Tp2 – outlet air temperature  
 Tw1 – inlet water temperature  
 Tw2 – outlet water temperature

Qw – water flow in the heat exchanger  
 Δpw – water pressure drop in the heat exchanger



SPECIAL PAINTING  
ON REQUEST

# AIR CURTAIN-FAN HEATER ELiS DUO

## Air curtain-fan heater **ELiS DUO**

Range [m]	2,5
Heating capacity [kW]	14,5–29,0
Air flow [m <sup>3</sup> /h]	1200–3700
Weight [kg]	23,9–41,1
Colour	grey, silver
Casing	steel, plastic



<sup>(1)</sup> According to ISO 27327-1

<sup>(2)</sup> For DUO-W at inlet/outlet water temperature 90/70°C, inlet air temperature 10°C

<sup>(3)</sup> RAL 9006 or RAL 9010

## APPLICATION

Modern design of the unit makes it especially suitable for buildings with high aesthetic values. Where there is a need of heating a room while providing an effective air barrier in the door opening, e.g. small grocery stores, petrol stations etc.

## AVAILABLE TYPES OF UNITS:

- **2 LENGTHS**  
1 m or 2 m
- **2 VERSIONS**
  - ⊕ water heat exchanger
  - ⚡ electric heaters

## TECHNICAL DATA

### Air curtain-fan heater ELiS DUO

	DUO-W-100	DUO-W-200	DUO-E-100
Power supply [V/Hz]	230 / 50	230 / 50	3 x 400 / 50
Max. power consumption [kW]	0,25	0,43	10,1
Max. current consumption [A]	1,1	1,85	14,7
IP	21/F	21/F	21/F
Connection ["]	½"	½"	½"
Curtain air flow stream [m <sup>3</sup> /h]	1400   700	3000   700	1400   700
Acoustic pressure level [dB(A)] <sup>(1)</sup>	58	58	60
Acoustic power level [dB(A)] <sup>(2)</sup>	73	73	75
Max. water temperature [°C]	95	95	–
Max. operating pressure [MPa]	1,6	1,6	–
Curtain's air temperature rise (ΔT) [°C] <sup>(3)</sup>	30	23	20
Unit weight [kg]	23,9	41,1	28,5
Range [m] <sup>(4)</sup>	2,5	2,5	2,5

<sup>(1)</sup> Average acoustic pressure level in the room of average sound absorption, volume of 1500 m<sup>3</sup>, at a distance of 5 m from the unit

<sup>(2)</sup> Acoustic power according to ISO 27327-2

<sup>(3)</sup> For DUO-W at heating medium temperature 90/70°C, at air inlet to the device 10°C / for DUO-E at air inlet to the device 10°C

<sup>(4)</sup> According to ISO 27327-1

# INSTALLATION



## DIMENSIONS

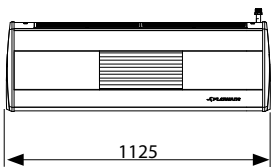

DUO-W/E-100

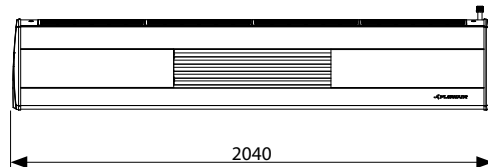

DUO-W-200

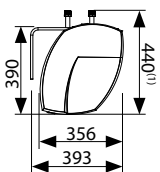

<sup>(1)</sup> The dimension refers to a curtain with an ELiS DUO-W exchanger.

For CAD drawings, Revit files and documentation for all available versions of ELiS visit [www.flowair.com](http://www.flowair.com)



---

# CONNECTION DIAGRAM

## I T-box CONTROLLER

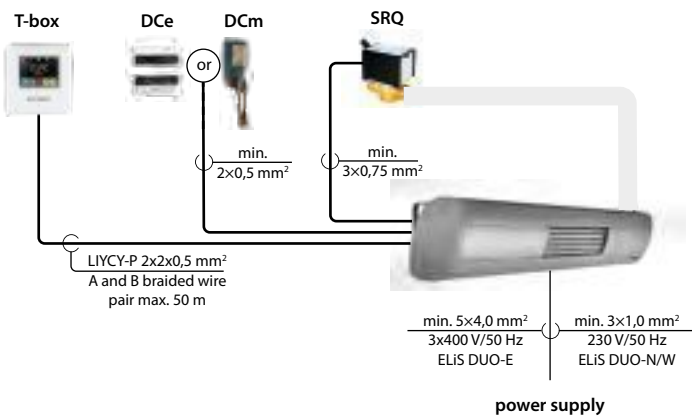

### ELEMENTS:

- T-box – intelligent controller with touch screen
- DCe – magnetic door sensor
- DCm – mechanical door sensor
- SRQ – valve with actuator

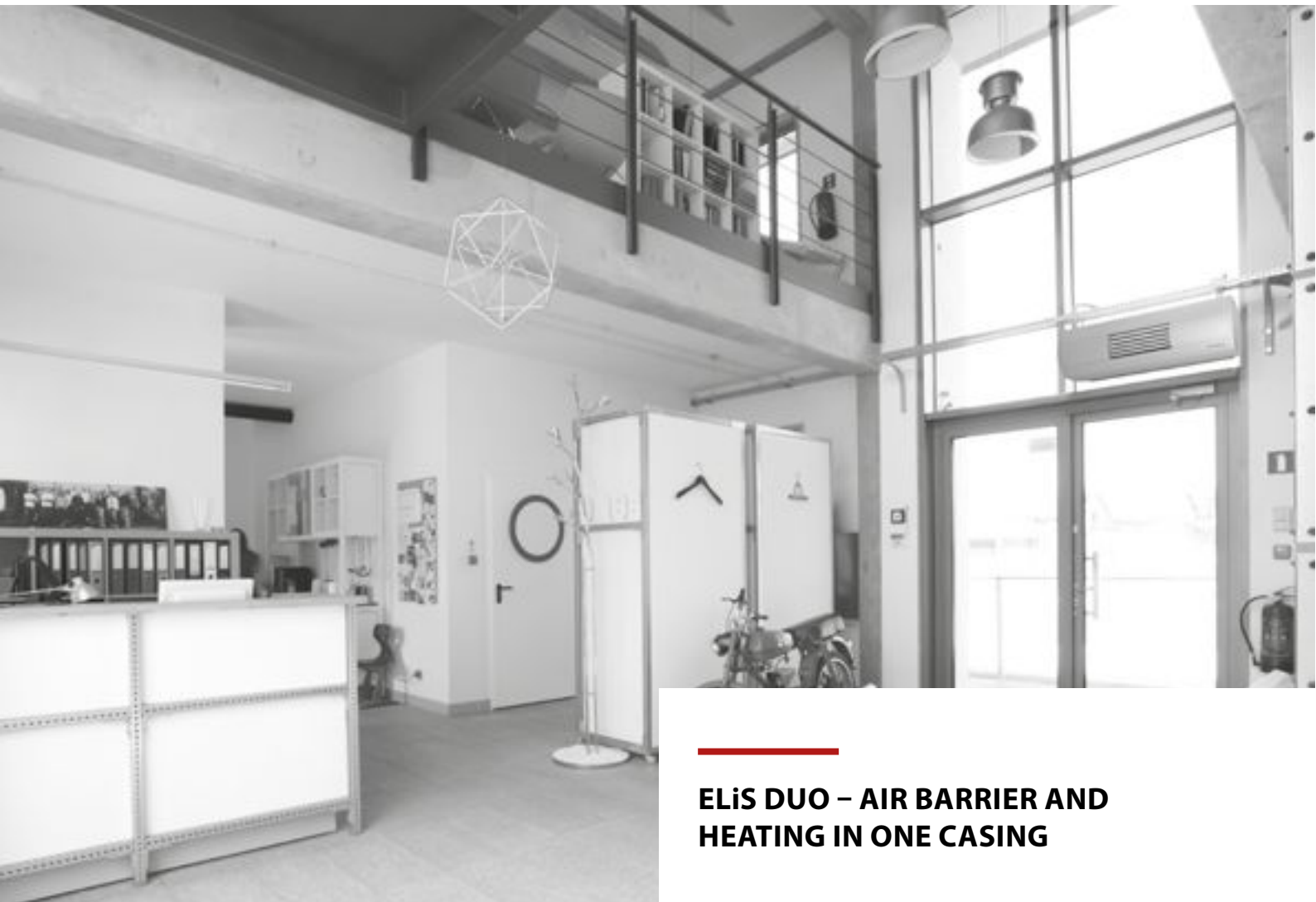

---

**ELIS DUO – AIR BARRIER AND  
HEATING IN ONE CASING**

# HEATING CAPACITIES

Tw1/Tw2 = 90/70°C							Tw1/Tw2 = 70/50°C						Tw1/Tw2 = 60/40°C					
Tp1	PK	PN	PC	Qw	Δpw	Tp2	PK	PN	PC	Qw	Δpw	Tp2	PK	PN	PC	Qw	Δpw	Tp2
[°C]	[kW]	[kW]	[kW]	[l/h]	[kPa]	[°C]	[kW]	[kW]	[kW]	[l/h]	[kPa]	[°C]	[kW]	[kW]	[kW]	[l/h]	[kPa]	[°C]
ELiS DUO-W-100																		
V = 2100 m <sup>3</sup> /h (curtain = 1400 m <sup>3</sup> /h; heater = 700 m <sup>3</sup> /h), III step																		
0	16,5	8,3	24,8	1095	11,9	35	11,9	5,9	17,8	778	6,7	25	9,5	4,7	14,2	620	4,6	20
10	14,5	7,2	21,7	956	9,3	41	9,7	4,9	14,6	638	4,7	31	7,3	3,7	11	477	2,9	26
20	12,3	6,2	18,5	817	7	46	7,5	3,8	11,3	496	3	36	5,1	2,5	7,6	331	1,5	31
ELiS DUO-W-200																		
V = 3700 m <sup>3</sup> /h (curtain = 3000 m <sup>3</sup> /h; heater = 700 m <sup>3</sup> /h), III step																		
0	26,6	6,6	33,2	1465	18,9	27	19,0	4,8	23,8	1 039	10,6	19	15,2	3,8	19	826	7,2	15
10	23,2	5,8	29	1280	14,7	33	15,6	3,9	19,5	851	7,3	25,5	11,7	2,9	14,6	637	4,5	21,5
20	19,8	5,0	24,8	1094	11	40	12,1	3,0	15,1	661	4,6	32	8,1	2,0	10,1	441	2,3	28

V – air flow

PK – heating capacity of curtain

PN – heating capacity of fan heater

PC – heating capacity of fan heater and curtain

PT – heating capacity

Tp1 – inlet air temperature

Tp2 – outlet air temperature

Tw1 – inlet water temperature

Tw2 – outlet water temperature

Qw – water flow in the heat exchanger

Δpw – water pressure drop in the heat exchanger

# AIR CURTAINS ELiS G



SPECIAL PAINTING  
ON REQUEST



## Air curtains ELiS G

Range [m]	7,5
Heating capacity [kW]	22,9–62,8
Air flow [m <sup>3</sup> /h]	4100–8600
Weight [kg]	43,0–67,0
Colour	grey, silver
Casing	galvanized steel

<sup>(1)</sup> According to ISO 27327-1

<sup>(2)</sup> For G-W at inlet/outlet water temperature 90/70°C, inlet air temperature 10°C

## APPLICATION

Warehouses, halls, logistics centers. ELiS G devices are intended for horizontal and vertical installation. They produce an air barrier that reduces the various losses associated with the exchange of air between the room and the outside area.

## AVAILABLE TYPES OF UNITS:

- **3 LENGTHS**  
0,5 m, 1,5 m or 2 m
- **3 VERSIONS**
  - ⊕ water heat exchanger (1- or 2-rows)
  - ⚡ without heating elements („ambient“)
  - Ⓝ electric heaters

## TECHNICAL DATA

### Air curtains

#### ELiS G

	G-N-50	G-W-150	G-W-150 2R	G-N-150	G-E-150	G-W-200	G-W-200 2R	G-N-200	G-E-200
Power supply [V/Hz]	230 / 50	230 / 50	230 / 50	230 / 50	3 x 400 / 50	230 / 50	230 / 50	230 / 50	3 x 400 / 50
Max. power consumption [kW]	0,34	0,69	0,69	0,69	12,0	1,0	1,0	1,0	20,0
Max. current consumption [A]	1,4	2,8	2,8	2,8	17,0	4,2	4,2	4,2	29,0
Fan IP	54	54	54	54	54	54	54	54	54
Connection	-	¾"	¾"	-	-	¾"	¾"	-	-
Curtain air flow stream [m <sup>3</sup> /h]	2500	6200	5700	6500	6300	8100	7600	8600	8200
Acoustic pressure level [dB(A)] <sup>(1)</sup>	64	66	66	66	66	68	68	68	68
Acoustic power level [dB(A)] <sup>(2)</sup>	79	81	81	81	81	83	83	83	83
Max. water temperature [°C]	-	130	130	-	-	130	130	-	-
Max. operating pressure [MPa]	-	1,6	1,6	-	-	1,6	1,6	-	-
Curtain's air temperature rise (ΔT) [°C] <sup>(3)</sup>	-	14	28	-	7	13	26	-	7
Unit weight [kg]	19,3	47,4	51,8	43,0	49,8	62,0	66,4	58,0	67,0
Range [m] <sup>(4)</sup>	7,5	7,0	7,0	7,5	7,0	7,0	7,0	7,5	7,0

<sup>(1)</sup> Average acoustic pressure level in the room of average sound absorption, volume of 1500 m<sup>3</sup>, at a distance of 5 m from the unit

<sup>(2)</sup> Acoustic power according to ISO 27327-2

<sup>(3)</sup> For G-W at heating medium temperature 90/70°C, at air inlet to the device 10°C / for G-E at air inlet to the device 10°C

<sup>(4)</sup> According to ISO 27327-1



# INSTALLATION

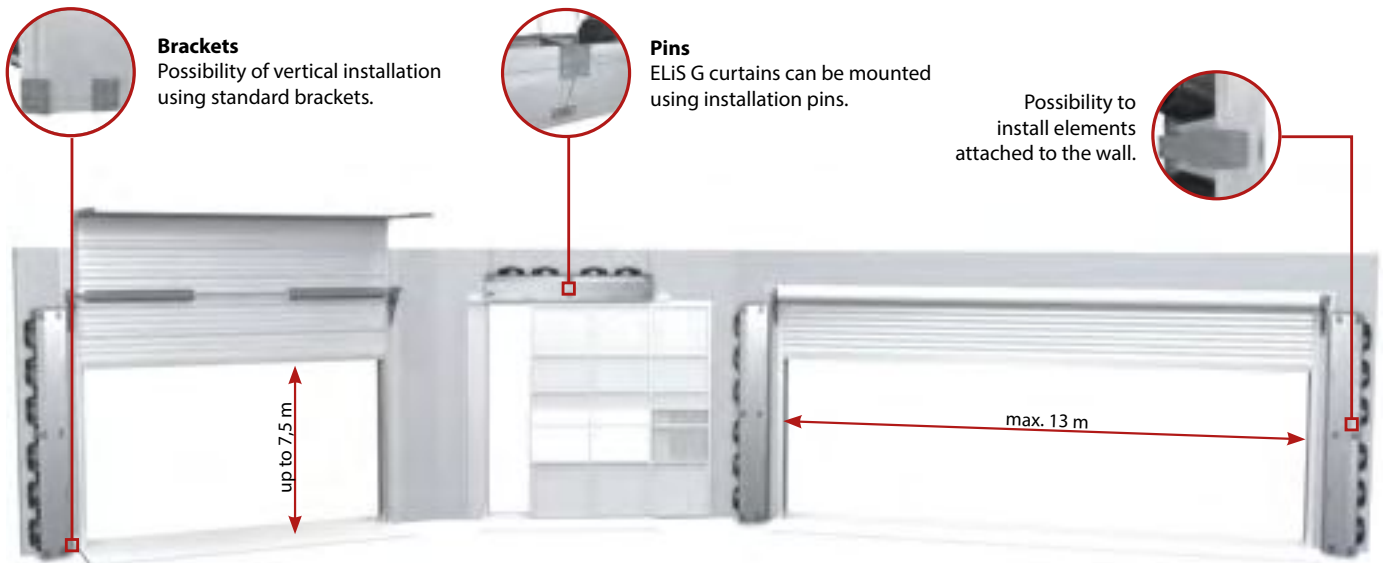

## DIMENSIONS

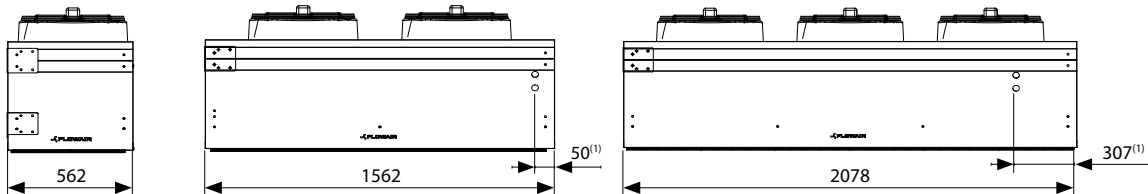

**G-50**

**G-150**

**G-200**

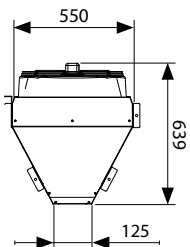

For CAD drawings, Revit files and documentation for all available versions of ELiS visit [www.flowair.com](http://www.flowair.com)



<sup>(1)</sup> The dimension refers to a curtain with an ELiS G-W exchanger.

# CONNECTION DIAGRAMS

## TS CONTROLLER

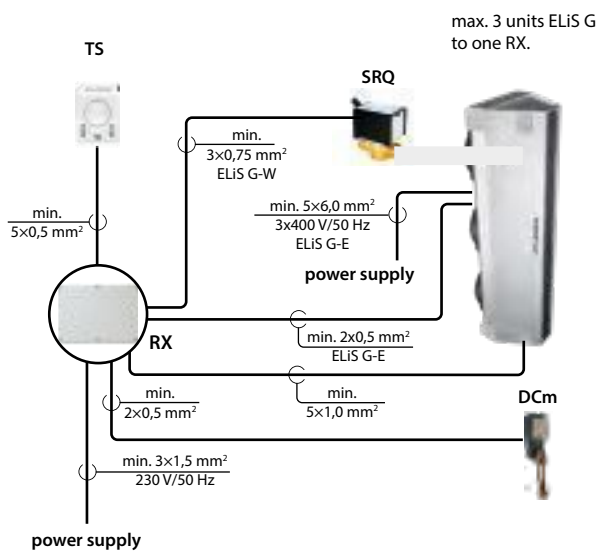

### ELEMENTS:

- **TS** – 3-step fan speed controller with thermostat
- **RX** – signal splitter for 3 ELiS G curtains
- **DCm** – mechanical door sensor
- **SRQ** – valve with actuator

## T-box CONTROLLER

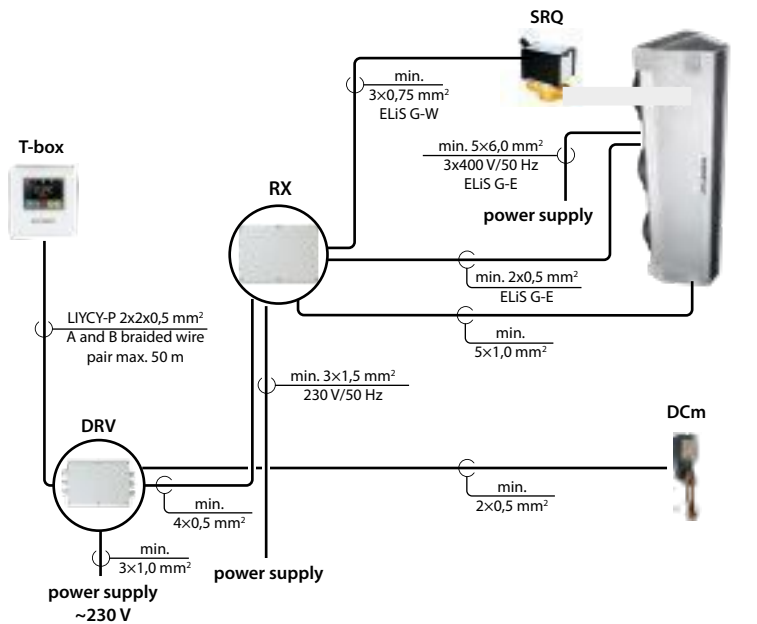

### ELEMENTS:

- **T-box** – intelligent controller with touch screen
- **DRV ELiS** – external control module
- **RX** – signal splitter for 3 ELiS G curtains
- **DCm** – mechanical door sensor
- **SRQ** – valve with actuator



**ELiS G – WHEN RANGE IS PRIORITY**

# HEATING CAPACITIES

Tw1/Tw2 = 90/70°C					Tw1/Tw2 = 80/60°C					Tw1/Tw2 = 70/50°C					Tw1/Tw2 = 60/40°C				
Tp1	PT	Qw	Δpw	Tp2	Tp1	PT	Qw	Δpw	Tp2	Tp1	PT	Qw	Δpw	Tp2	Tp1	PT	Qw	Δpw	Tp2
°C	kW	l/h	kPa	°C	°C	kW	l/h	kPa	°C	°C	kW	l/h	kPa	°C	°C	kW	l/h	kPa	°C
ELIS G-W-150																			
V = 6200 m³/h, III step																			
0,0	34,8	1530	9	15,5	0,0	29,9	1310	7	13,5	0,0	25	1090	6	11	0,0	20,1	880	4	9
10,0	29,5	1300	6	23,5	10,0	24,8	1090	6	21,5	10,0	20	870	4	19,5	10,0	15,1	660	4	17
20,0	24,5	1080	6	32	20,0	19,8	870	4	29,5	20,0	15,1	660	4	27,5	20,0	10,4	450	4	25
ELIS G-W-200																			
V = 8100 m³/h, III step																			
0,0	38,9	1720	9	14,5	0,0	33,5	1470	8	12	0,0	28	1220	6	10	0,0	22,4	980	5	8
10,0	33,1	1460	8	22,5	10,0	27,7	1220	6	20,5	10,0	22,3	980	5	18,5	10,0	16,9	740	5	16,5
20,0	27,4	1210	6	31	20,0	22,1	970	5	28,5	20,0	16,9	740	5	26,5	20,0	11,6	500	2	24,5
ELIS G-W-150 2R																			
V = 5700 m³/h, III step																			
0,0	65,2	2870	4	32	0,0	56	2460	4	27	0,0	46,6	2040	3	23	0,0	37,3	1620	2	18
10,0	55,3	2440	4	38	10,0	46,2	2030	3	33	10,0	37,1	1620	2	29	10,0	27,9	1220	2	24
20,0	45,7	2020	3	44	20,0	36,8	1620	2	39	20,0	28	1220	2	35	20,0	19	830	2	30
ELIS G-W-200 2R																			
V = 7600 m³/h, III step																			
0,0	74,2	3270	5	29	0,0	63,5	2790	4	25	0,0	52,9	2310	4	21	0,0	42,2	1840	3	17
10,0	62,8	2770	4	36	10,0	52,5	2300	4	31	10,0	42,1	1840	3	27	10,0	31,6	1380	3	23
20,0	52	2290	4	42	20,0	41,9	1840	3	38	20,0	31,7	1390	3	33	20,0	21,4	930	2	29

V – air flow  
 PT – heating capacity  
 Tp1 – inlet air temperature

Tp2 – outlet air temperature  
 Tw1 – inlet water temperature  
 Tw2 – outlet water temperature

Qw – water flow in the heat exchanger  
 Δpw – water pressure drop in the heat exchanger

# CONTROL SYSTEMS

for ELiS air curtains



## TS CONTROLLER

basic version

Simplest regulation of 3-step fans. Air curtain operation is controlled by 3-step fan speed controller with thermostat.



## T-box CONTROLLER

BMS version

Intelligent regulation system of 3-step fans. Speed regulation of energy-efficient fan via T-box controller.

## AIR CURTAINS ELiS



TS Controller



T-box Controller

### Controlling options

	TS Controller	T-box Controller
Type of devices	ELiS C, ELiS T, ELiS B, ELiS A, ELiS G	ELiS T <sup>(1)</sup> , ELiS C <sup>(1)</sup> , ELiS A, ELiS B, ELiS DUO, ELiS G <sup>(1)</sup>
Manual 3-step air flow regulation	✓	✓
<b>Modes</b>		
Heating/Ventilation	✓	✓
Operation depending on door sensor and temperature	✓	✓
Weekly programmer		✓
BMS		✓
Switch-off delay		✓
Idle speed mode		✓
INTEGRATION WITH FLOWAIR SYSTEM		✓
<b>Max. number of connected units</b>		
Via controller	ELiS T / C – 2, ELiS A / B / DUO – 5, ELiS G – 1	31
Via additional splitters	ELiS G – 9, ELiS T / C <sup>(2)</sup> – 18	n/d
<b>Type of fan</b>		
AC – standard 3-step fan	✓	✓

<sup>(1)</sup> External control module DRV ELiS required

<sup>(2)</sup> According to ELiS C-W

# CONTROL ELEMENTS

## DOOR SENSORS



Door sensors inform the control system about the opening / closing of the door.

Compatibility of sensors with ELiS air curtains

Sensor	ELiS C	ELiS T	ELiS B	ELiS A	ELiS DUO	ELiS G
DCet	✓	✓				
DCe			✓	✓	✓	
DCm	✓	✓	✓	✓	✓	✓

## VALVES SRQ



Two or three-way valves with an electric actuator are available to control the flow of the heating medium.

Compatibility of valves with ELiS air curtains

Valve	ELiS C	ELiS T	ELiS B	ELiS A	ELiS DUO	ELiS G
SRQ2d 1/2"		✓	✓	✓	✓	
SRQ2d 3/4"	✓					✓
SRQ3d 1/2"		✓	✓	✓	✓	
SRQ3d 3/4"	✓					✓

## RX SPLITTERS

Control signal distributor for connecting several ELiS G air curtains with 3-stage fans to one controller.

The maximum number of devices supported by one controller

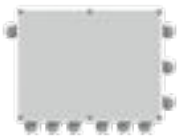

Splitters	ELiS G	ELiS T	ELiS C-W
1 pcs. RX	3	6	6
2 pcs. RX	6	12	12
3 pcs. RX	7	18	18

# INSTALLATION ELEMENTS

## CONSOLE ELiS



For horizontal mounting ELiS T, ELiS A, curtain heater ELiS DUO. Available in silver or white colors.

## MPK SET

for ELiS T



For vertical mounting ELiS T curtain. Available in silver color.

## MPK SET

for ELiS C



For vertical mounting ELiS C-W and ELiS C-E curtain. Available in white color.



---

# DUCTLESS VENTILATION WITH HEAT RECOVERY



# VENTILATION UNIT OXeN

## Ventilation unit OXeN

Efficiency of heat recovery [%]	80,9
Air flow [m <sup>3</sup> /h]	150–1200
Weight [kg]	75,1–82,5
Colour	grey
Casing	EPP

<sup>(1)</sup> According to ISO 27327-1

<sup>(2)</sup> For G-W at inlet/outlet water temperature 90/70°C, inlet air temperature 10°C



## APPLICATION

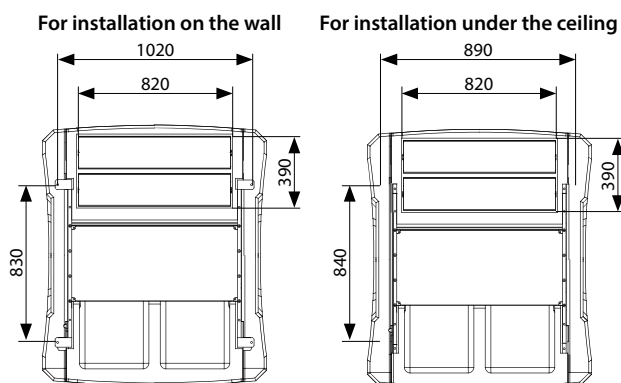
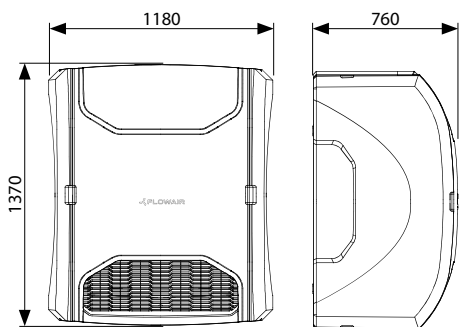

Medium cubature buildings, where fresh air supply is demanded and where air duct installation is unfounded, e.g. gas stations, stores, workshops, warehouses, sports halls etc.

## DIMENSIONS





## AVAILABLE MODELS

### INSTALLATION ON THE WALL

-  X2-N-1.2-V – unit without additional air heating wall mounted
-  X2-W-1.2-V – unit with air heating by water heater wall mounted
-  X2-E-1.2-V – unit with air heating by electric heater wall mounted

### INSTALLATION UNDER THE CEILING

-  X2-N-1.2-H – unit without additional air heating mounted under the ceiling
-  X2-W-1.2-H – unit with air heating by water heater mounted under the ceiling

For CAD drawings, Revit files and documentation for all available versions of OXeN visit [www.flowair.com](http://www.flowair.com)





## TECHNICAL DATA

Ventilation units <b>OXeN</b>	<b>X2-W-1.2-V</b>	<b>X2-N-1.2-V</b>	<b>X2-W-1.2-H</b>	<b>X2-N-1.2-H</b>	<b>X2-E-1.2-V</b>
Max. air flow stream inlet/outlet <sup>(1)</sup> [m <sup>3</sup> /h]	1200	1200	1200	1200	1200
Air stream range <sup>(2)</sup> [m]	15 <sup>(2)</sup>	15 <sup>(2)</sup>	4,5 <sup>(3)</sup>	4,5 <sup>(3)</sup>	15 <sup>(2)</sup>
Air flow regulation inlet/outlet [m <sup>3</sup> /h]	stepless, 150–1200	stepless, 150–1200	stepless, 150–1200	stepless, 150–1200	stepless, 150–1200
Acoustic pressure level <sup>(4)</sup> [dB(A)]	49	49	49	49	49
Power supply [V/Hz]	230/50	230/50	230/50	230/50	3x400/50
Max. current consumption [A]	1,9	1,9	1,9	1,9	14,0
Max. power consumption [kW]	0,42	0,42	0,42	0,42	8,5
Weight of unit [kg]	77,5	75,1	80,5	78,1	82,5
Weight of unit filled with water [kg]	78,3	–	81,3	–	–
Place of installation	indoors	indoors	indoors	indoors	indoors
Max. air contamination [g/m <sup>3</sup> ]	0,3	0,3	0,3	0,3	0,3
Operating temperature [°C]	5–45	5–45	5–45	5–45	5–45
Installation position	on the wall	on the wall	under the ceiling	under the ceiling	on the wall
IP	42	42	42	42	42
Filter class	EU4	EU4	EU4	EU4	EU4
Type of heat recovery exchanger	two-step heat recovery in cross heat exchangers	two-step heat recovery in cross heat exchangers	two-step heat recovery in cross heat exchangers	two-step heat recovery in cross heat exchangers	two-step heat recovery in cross heat exchangers
Thermal efficiency dry / wet <sup>(5)</sup> [%]	74,7 / 80,9	74,7 / 80,9	74,7 / 80,9	74,7 / 80,9	74,7 / 80,9
Type of additional heater	water heater	–	water heater	–	electric heater
Nominal heating capacity <sup>(6)</sup> [kW]	10	–	10	–	8,5
Connection ["]	½	–	½	–	–
Max. water pressure [MPa]	1,6	–	1,6	–	–
Max. water temperature [°C]	95	–	95	–	–
Control system	controller with touch screen	controller with touch screen	controller with touch screen	controller with touch screen	controller with touch screen
Antifreeze protection of heat recovery exchanger	reduction of fan revs	reduction of fan revs	reduction of fan revs	reduction of fan revs	reduction of fan revs
Antifreeze protection of water heat exchanger	temperature measurement of supplied air and water by PT-1000 sensor	–	temperature measurement of supplied air and water by PT-1000 sensor	–	–

<sup>(1)</sup> Max. air flow during operation with EU4 filter and OxS air inlet

<sup>(2)</sup> Range of horizontal isothermal air stream, at 0,2 m/s velocity limit

<sup>(3)</sup> Range of vertical nonisothermal air stream at T= Δ5 °C, at 0,2 m/s velocity limit

<sup>(4)</sup> Acoustic pressure level at the distance of 5 m from the unit, in the room of medium capability of sound absorption and 500 m<sup>3</sup> of cubature

<sup>(5)</sup> According to directive (UE) NR 1253/2014 measured with balanced mass flow, an indoor-outdoor air temperature difference of 20 K and the airflow 1200m<sup>3</sup>/h

<sup>(6)</sup> At water temperature 80/60°C, inlet air temperature 5°C and 1200 m<sup>3</sup>/h of air flow

# CONTROL SYSTEM

OXeN heat recovery unit is equipped with a complete control system.



### T-box

Controller with touch screen:

- Intuitive use
- Quick setting of desired parameters
- Full control of operating status of the unit
- Control of over up to 31 units simultaneously
- Integration with **FLOWAIR SYSTEM**



## I OPERATING MODES



weekly programmer

### AUTO

automatic regulation of supplied air temperature



COMFORT / ECO only one-click to change operating parameters!



filter status measured by differential pressure sensor



antifreeze protection



compatibility with BMS MODBUS RTU system



operation with or without heat recovery

# INSTALLATION

## I INSTALLATION ON THE WALL

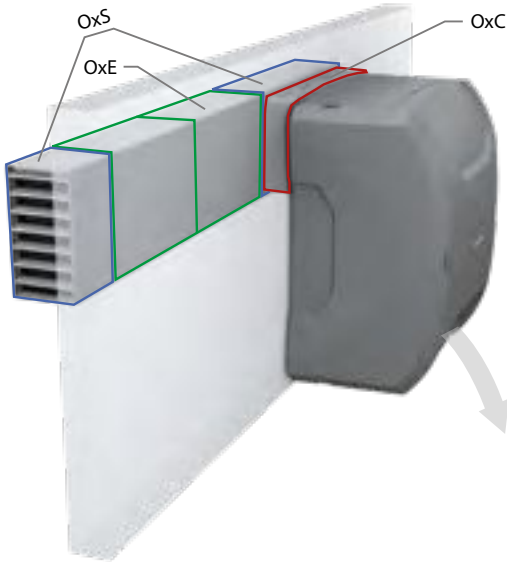

Possibility to install the OxS air inlet/outlet on both sides.

- **OxS** – wall-mounted air inlet/outlet
- **OxE** – extension duct
- **OxC** – wall crossing (one piece as standard with OXeN)
- **OxS-H** – roof-mounted air inlet/outlet
- **OxPD-H** – roof base
- **OxCB-H** – insulated roof curb for straight roofs
- **OxCBs-H** – insulated roof curb for pitched roofs
- **OxE-H** – extension duct
- **OxC2-H** – connection adapter (included in the set)

## I INSTALLATION UNDER THE CEILING

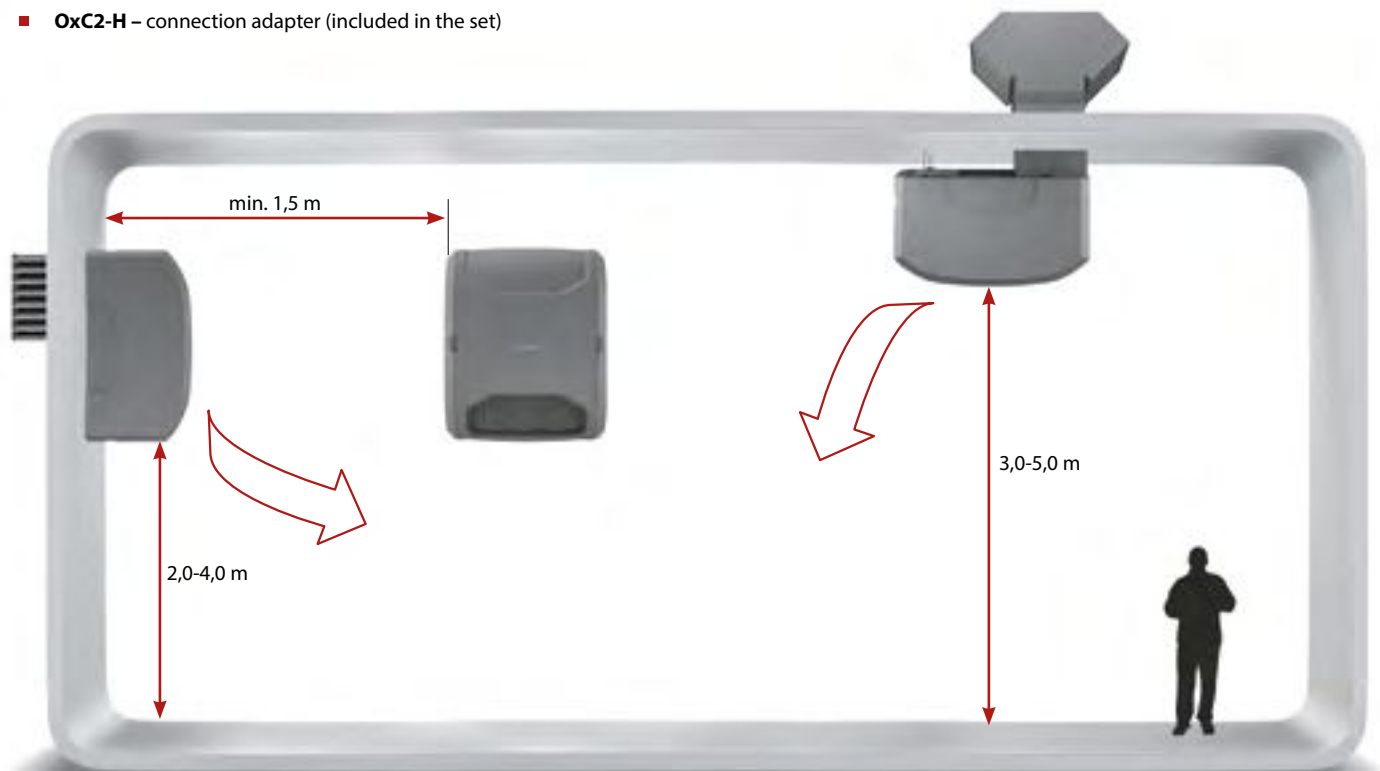
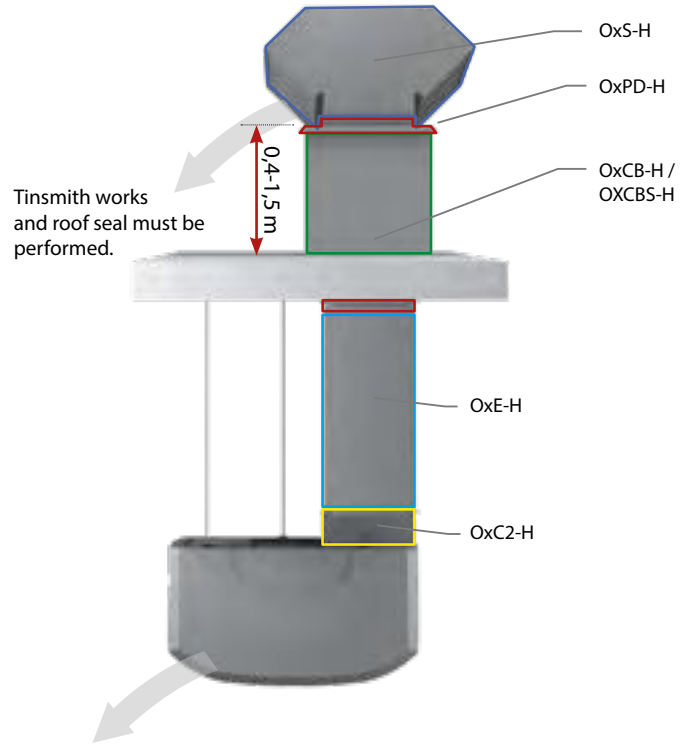

# NOMOGRAM OF HEATING CAPACITY

FOR MAX. AIR FLOW 1200 M<sup>3</sup>/H

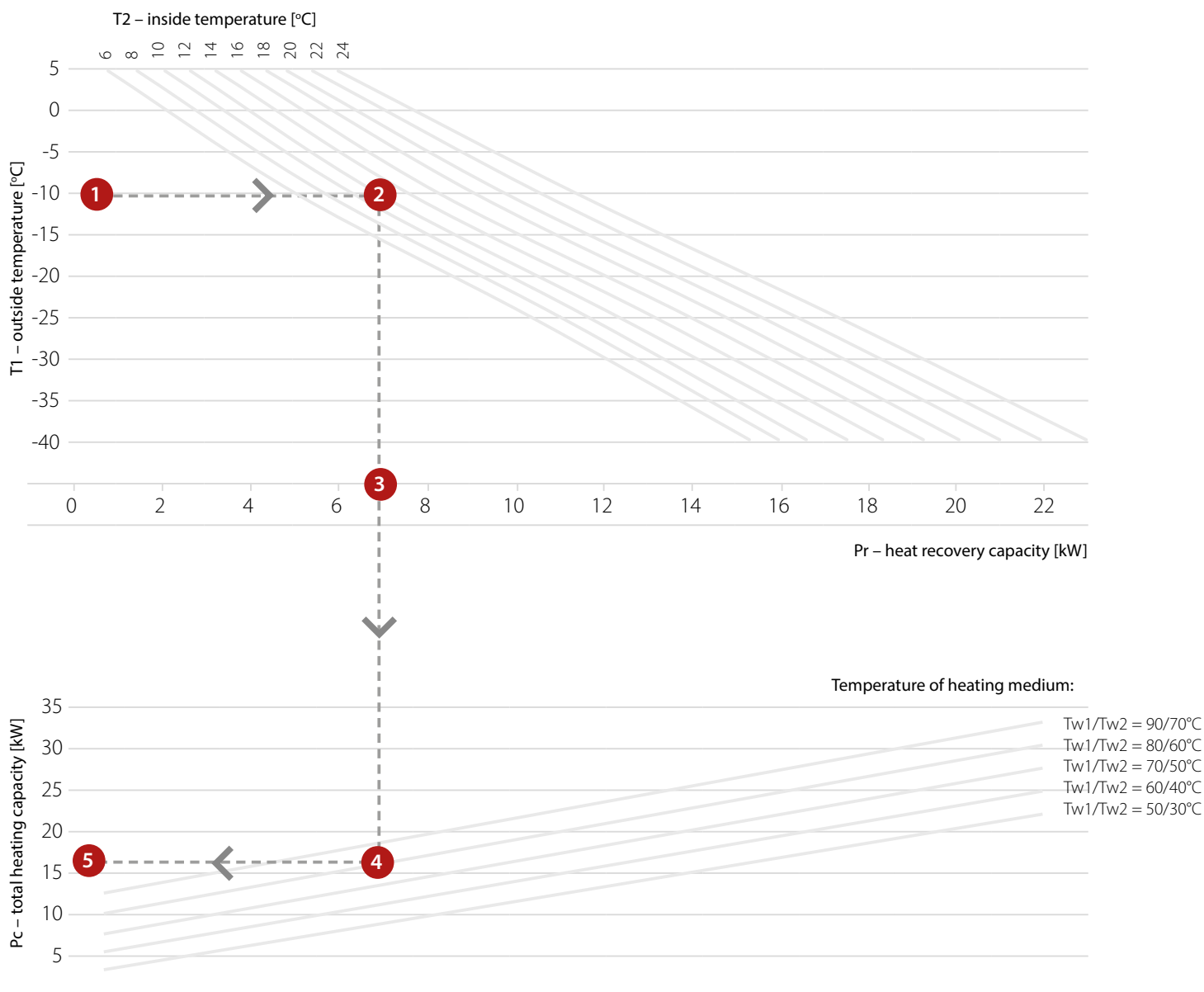

1. Specify outside temperature
2. Specify inside temperature
3. Read the capacity of heat recovery Pr (total heating capacity of OXeN without water heat exchanger X2-N-1.2)
4. Specify heating medium temperature
5. Read the total heating capacity Pc (for OXeN with water heat exchanger X2-W-1.2)

Air parameters: supplied air RH 90%, removed air RH 30%, air flow 1200 m<sup>3</sup>/h

# NOMOGRAM OF AIR FLOW TEMPERATURE

FOR MAX. AIR FLOW 1200 M<sup>3</sup>/H

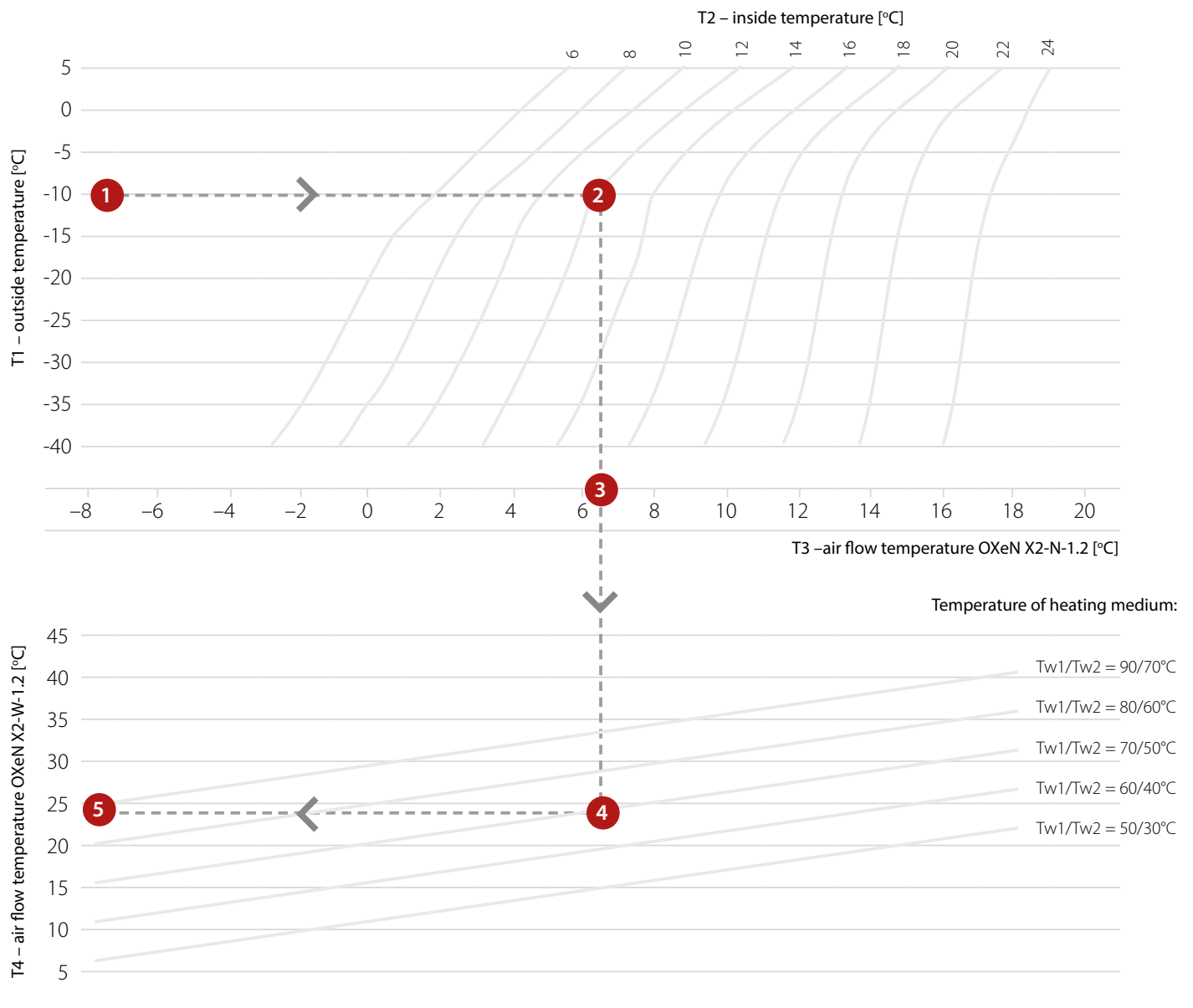

1. Specify outside temperature
2. Specify inside temperature
3. Read the air flow temperature for OXeN without water heat exchanger
4. Specify heating medium temperature
5. Read the air flow temperature for OXeN with water heat exchanger

Air parameters: supplied air RH 90%, removed air RH 30%, air flow 1200 m<sup>3</sup>/h



---

# ROOFTOP UNITS



# ROOFTOP UNITS

## Cube

### DUCT INSTALLATION

#### Cube 20 – 160

3 in 1



#### Cube R8



### DUCTLESS INSTALLATION

#### Cube NW



### APPLICATION

Various options and various mounting possibilities together with high disposal pressure guarantee a wide range of application. For example shopping malls, logistic centers, industrial facilities, petrol stations or supermarkets.

### FUNCTIONS

- cooling
- heating
- ventilation with heat recovery

### FEATURES

#### COMPACT



All components needed for complex air processing (thermal treatment and ventilation with heat recovery) are included in one casing.

#### ECODESIGN



The device fulfills the requirements concerning eco project and ventilation system UE nr 1253/2014, cooling devices UE nr 2016/2281 and is characterized by class A energy efficiency.

#### DECENTRALISATION



Using several units instead of one main unit enables independent regulation and increases the reliability of the whole system. It also ensures even, weight distribution on the roof construction.













#### 3 YEARS WARRANTY AND ON-LINE ACCESS



There is an option to monitor and control the device on line with a GSM router and to extend the warranty to 3 years.



## TECHNICAL DATA

		Cooling		Heating			Ventilation with heat recovery		
		Cooling <sup>(1)</sup>	Heat pump <sup>(1)</sup>	Water heater <sup>(2)</sup>	Gas heaters		Electric heaters	Nominal airflow / external pressure	Fresh air airflow / ErP 2018 heat recovery efficiency <sup>(3)</sup>
			HP	W	G	Gm	E		
		kW	kW	kW	kW / kW	kW - kW	kW	m <sup>3</sup> /h / Pa	m <sup>3</sup> /h / %
	Cube 20 ⊖ ⊕ ⊕	20,3	19,3	50,9	40,2 / 20,4	33,5 - 5,0	25,0	5000 / 350	5000 / 78,5
	Cube 40 ⊖ ⊕ ⊕	41,8	41,5	74,0	47,9 / 25,8	40,5 - 8,1	25,0	8000 / 350	8000 / 73,1
	Cube 50 ⊖ ⊕ ⊕	57,0	53,9	111,0	92,3 / 56,2	97,2 - 13,4	od 25,0	14000 / 350	14000 / 73,7
	Cube 60 ⊖ ⊕ ⊕	64,4	61,4	120,0	92,3 / 56,2	97,2 - 13,4	od 25,0	16000 / 350	15000 / 73,0
	Cube 80 ⊖ ⊕ ⊕	79,4	76,5	158,0	92,3 / 56,2	97,2 - 17,8	od 25,0	19000 / 350	17000 / 73,3
	Cube 100 ⊖ ⊕ ⊕	90,0	87,0	167,0	92,3 / 56,2	97,2 - 17,8	od 25,0	21000 / 350	17000 / 73,3
	Cube 120 ⊖ ⊕ ⊕	134,4	126,8	182,0	92,3 / 76,8	97,2 - 17,8	od 25,0	24000 / 350	20000 / 73,0
	Cube 160 ⊖ ⊕ ⊕	155,6	152,0	199,0	92,3 / 76,8	97,2 - 17,8	od 25,0	28000 / 350	20000 / 73,0
	Cube R8 ⊕ ⊕	n/a	n/a	74,0	47,9 / 20,3	40,5 - 5,0	25,0	8000 / 350	8000 / 73,1
	Cube 20 / NW ⊖ ⊕ ⊕	20,3	19,3	50,9	40,2 / 20,4	33,5 - 5,0	25,0	5000 / n/a	5000 / 78,5
	Cube 40 / NW ⊖ ⊕ ⊕	41,8	41,5	74,0	47,9 / 25,8	40,5 - 8,1	25,0	8000 / n/a	8000 / 73,1
	Cube R8 / NW ⊕ ⊕	n/a	n/a	74,0	47,9 / 20,3	40,5 - 5,0	25,0	8000 / n/a	8000 / 73,1

⊖ cooling    ⊕ heating    ⊕ ventilation with heat recovery

<sup>(1)</sup> Cooling - outside temperature 35°C [TS], inlet temperature 27°C [TS] / 19°C [TM]. Heating - outside temperature 7°C [TS], 6°C [TM], inlet temperature 20°C [TS]. TS - dry thermometer, TM - liquid thermometer, net EER - net cooling capacity / overall power consumption, net COP = net heating capacity / overall power consumption.

<sup>(2)</sup> Heating medium parameters 70/50°C and inlet air temperature 8°C.

<sup>(3)</sup> According to UE 1253/2014 regulation. Inlet/outlet air temperature difference 20K, dry air.

We reserve the right to change technical data and design parameters.

---

# EXAMPLES OF SYSTEM FLOWAIR

## I WAREHOUSES AND PRODUCTION HALL

### Heating and gate curtain

The requirement was to provide thermal comfort even during opening of the gate. Thanks to FLOWAIR SYSTEM integration of ELIS T air curtains and LEO fan heaters is easy. Beside their standard operation controlled by a temperature sensor, LEO fan heaters have an additional functionality: Upon opening of the gate both the ELIS T air curtain and the LEO fan heater switch on providing thermal comfort even during long openings of the gate.



## I PRODUCTION HALL

### Emergency ventilation design

The requirement was to ensure a proper heating and ventilation in the hall, depending on the humidity level of the air inside the building. In addition, the client wanted to check and control the parameters of all devices (incl., LEO KM 15 pcs) using only one controller.



## I HOTEL

### Personalization of curtains for a representative object

The hotel is connected with a shopping center, service center and the railway station in Sopot. All curtains together (ELiS T, ELiS A, and air curtain-fan heater combo units ELiS DUO) form the FLOWAIR System and are controlled by one T-box controller. Thanks to the weekly programmer, you can automatically switch all devices ON/OFF, according to the user's needs and change the mode of their operation.



## I PRODUCTION HALL

### Heating and ductless ventilation

A warehouse for raw materials with an area of nearly 15,000 m<sup>3</sup>, has been modernized and turned into a production hall. Due to the architectural constraints and light construction of the building, ventilation was provided by Oxen's – compact, light, wall-mounted ventilation units with heat recovery. Additionally, to minimize heat losses, the system included LEO fan heaters and ELiS G industrial door curtains.





General importer and distributor for the Republic of Croatia

Termolider d.o.o.

a. Lastovska ulica 2A, 10 000 Zagreb, Republic of Croatia

t. +385 1 55 73 585

e. [info@termolider.hr](mailto:info@termolider.hr)

w. [www.termolider.eu](http://www.termolider.eu)



for inquiries:  
[info@termolider.hr](mailto:info@termolider.hr)